

Rauland Invest AS Holtarvegen Veg2 Tverrprofil	Tegnet av AST	Saksbehandler
	Sidemannskontr.	Prosjektansvarlig AST
	Dato 03.12.2009	Målestokk 1: 200
	Prosj.nr. 2219-V2	1: 200
Plankontoret H. Homme AS 4747 Valle Tlf: 37 93 70 00, Fax: 37 93 74 74, E-Post: post@plankontoret.no	Tegn.nr. TP-1	Rev.

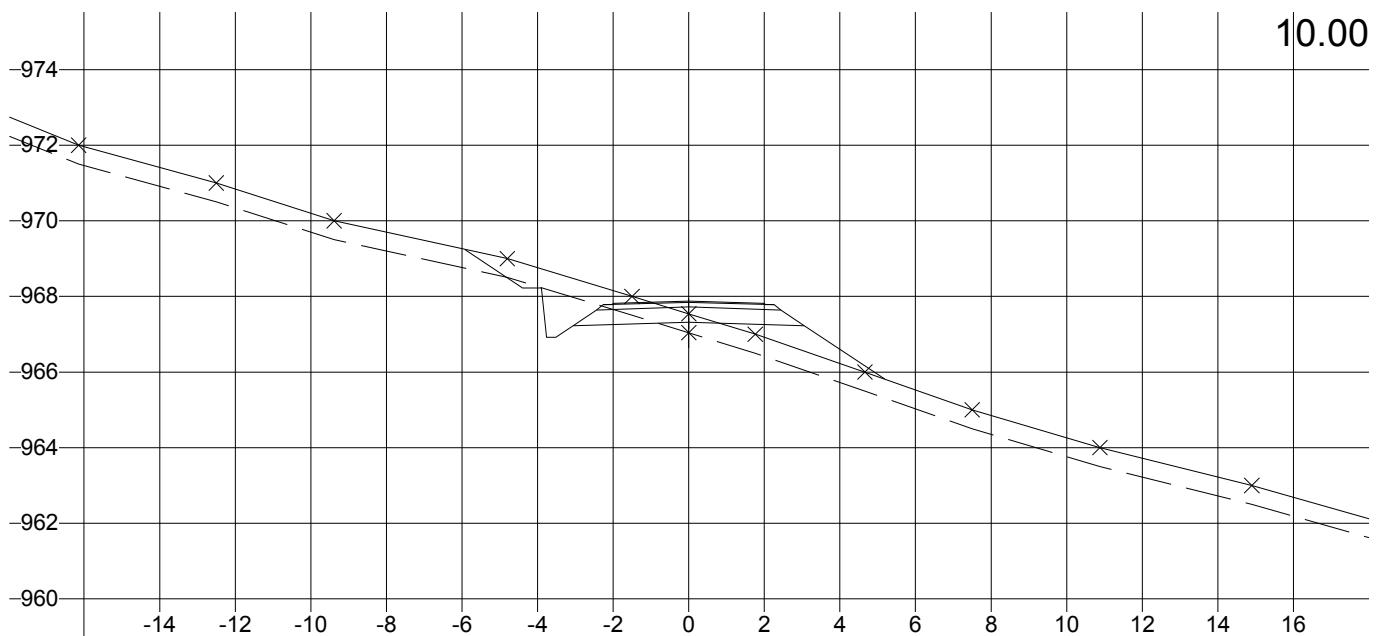

L:\IMA 4.7, Lisens: Plankontoret Hallvard Homme AS, Parsell: Parsell2.psl

Rauland Invest AS Holtarvegen Veg2 Tverrprofil	Tegnet av AST	Saksbehandler
	Sidemannskontr.	Prosjektansvarlig AST
Plankontoret H. Homme AS 4747 Valle Tlf: 37 93 70 00, Fax: 37 93 74 74, E-Post: post@plankontoret.no	Dato 03.12.2009	Målestokk 1: 200
	Prosj.nr. 2219-V2	1: 200
	Tegn.nr. Tp-2	Rev.

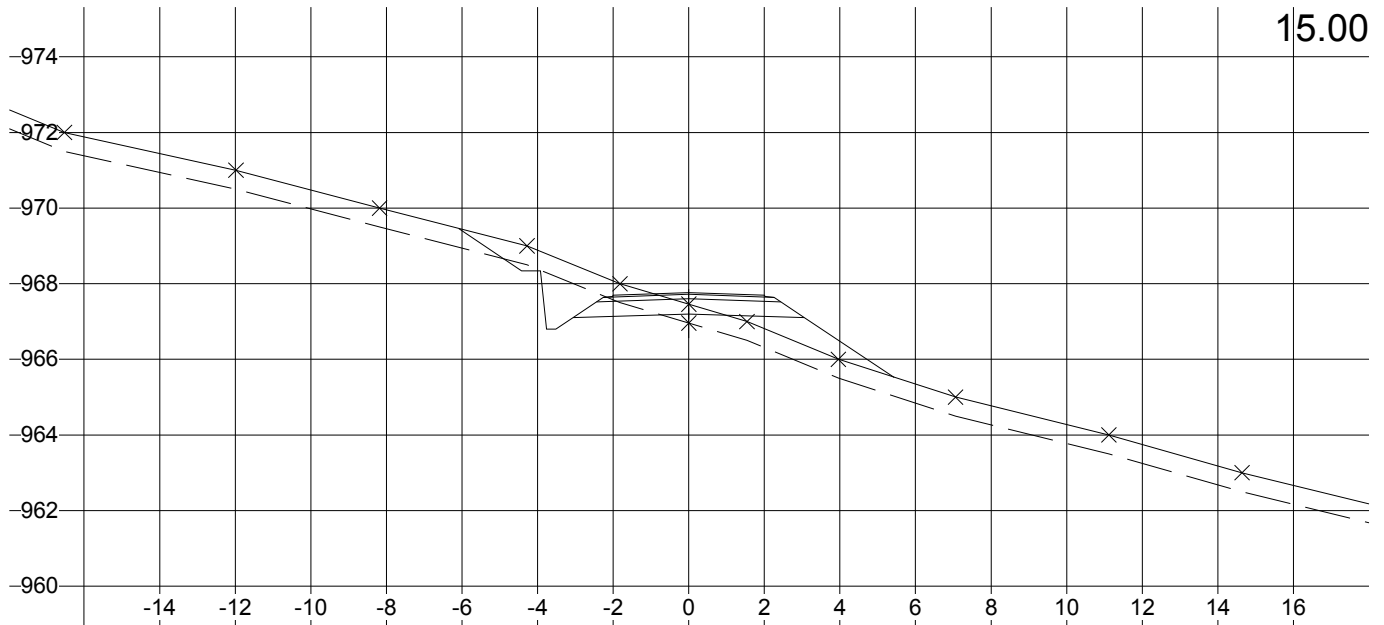
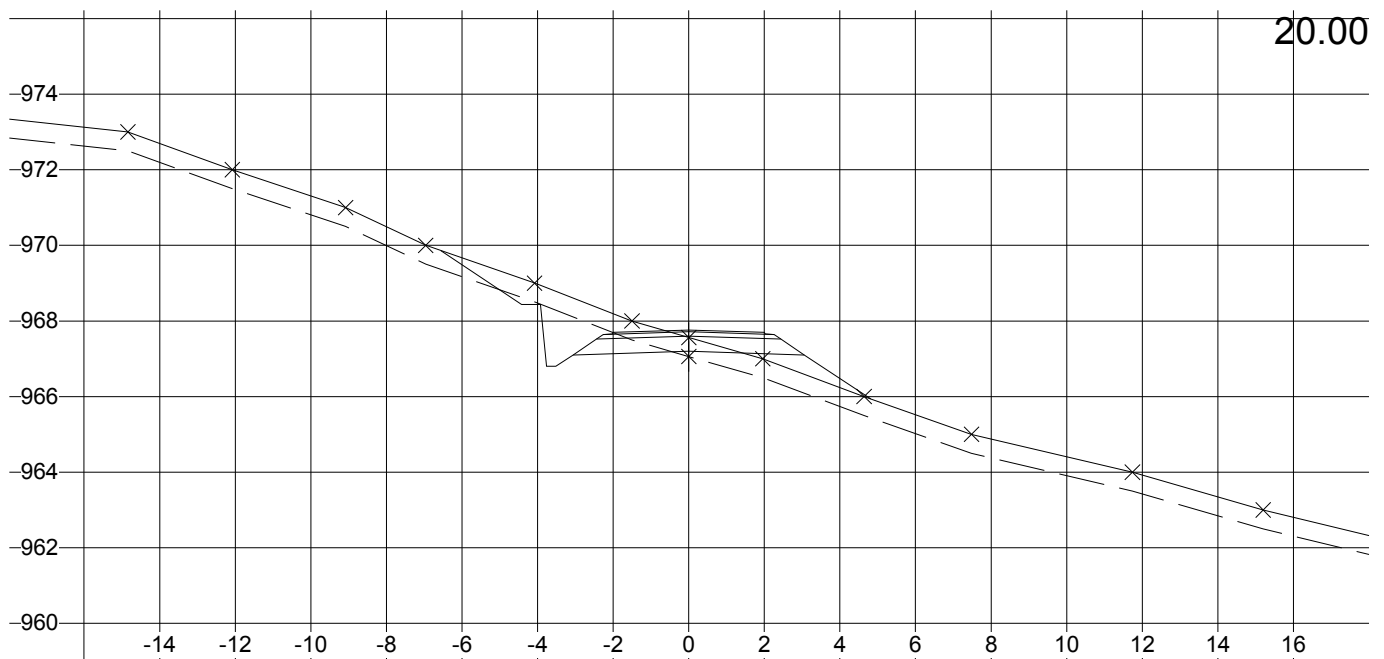
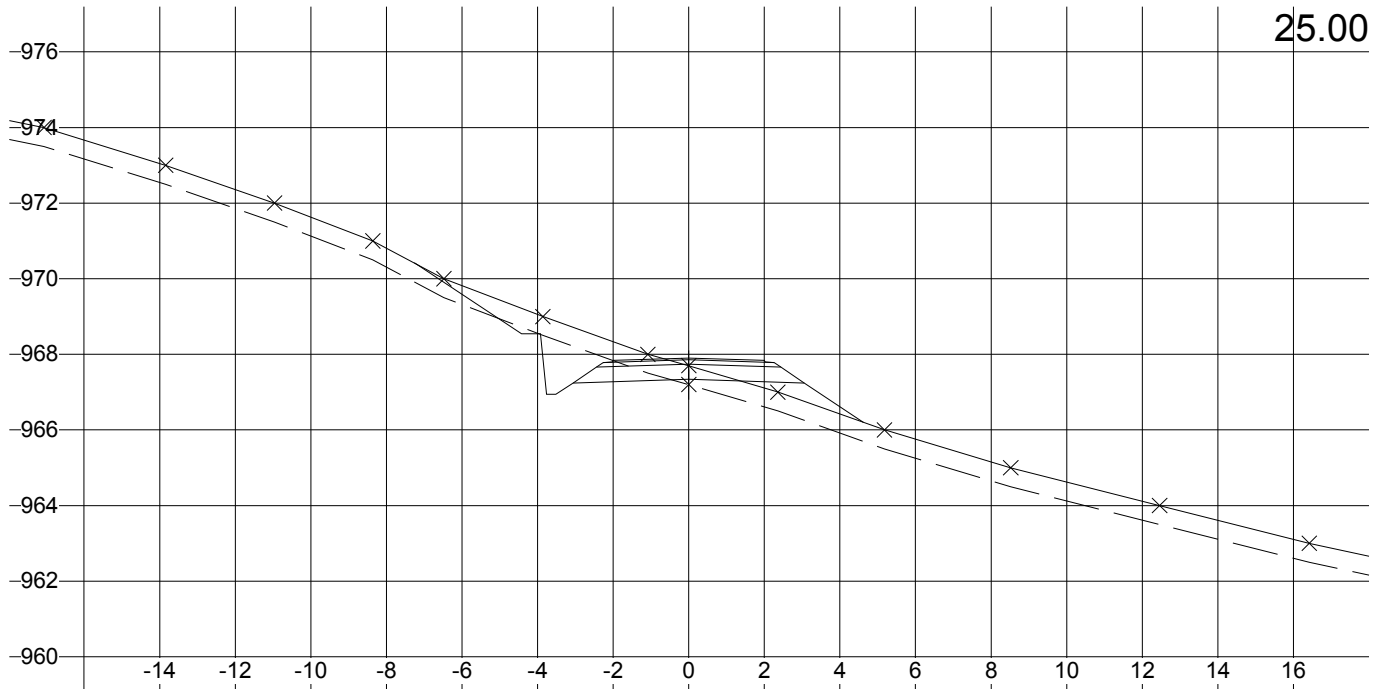

L:\IMA 4.7, Lisens: Plankontoret Hallvard Homme AS, Parsell: Parsell2.psl

Rauland Invest AS Holtarvegen Veg2 Tverrprofil	Tegnet av AST	Saksbehandler
	Sidemannskontr.	Prosjektansvarlig AST
Plankontoret H. Homme AS 4747 Valle Tlf: 37 93 70 00, Fax: 37 93 74 74, E-Post: post@plankontoret.no	Dato 03.12.2009	Målestokk 1: 200
	Prosj.nr. 2219-V2	1: 200
	Tegn.nr. Tp-3	Rev.

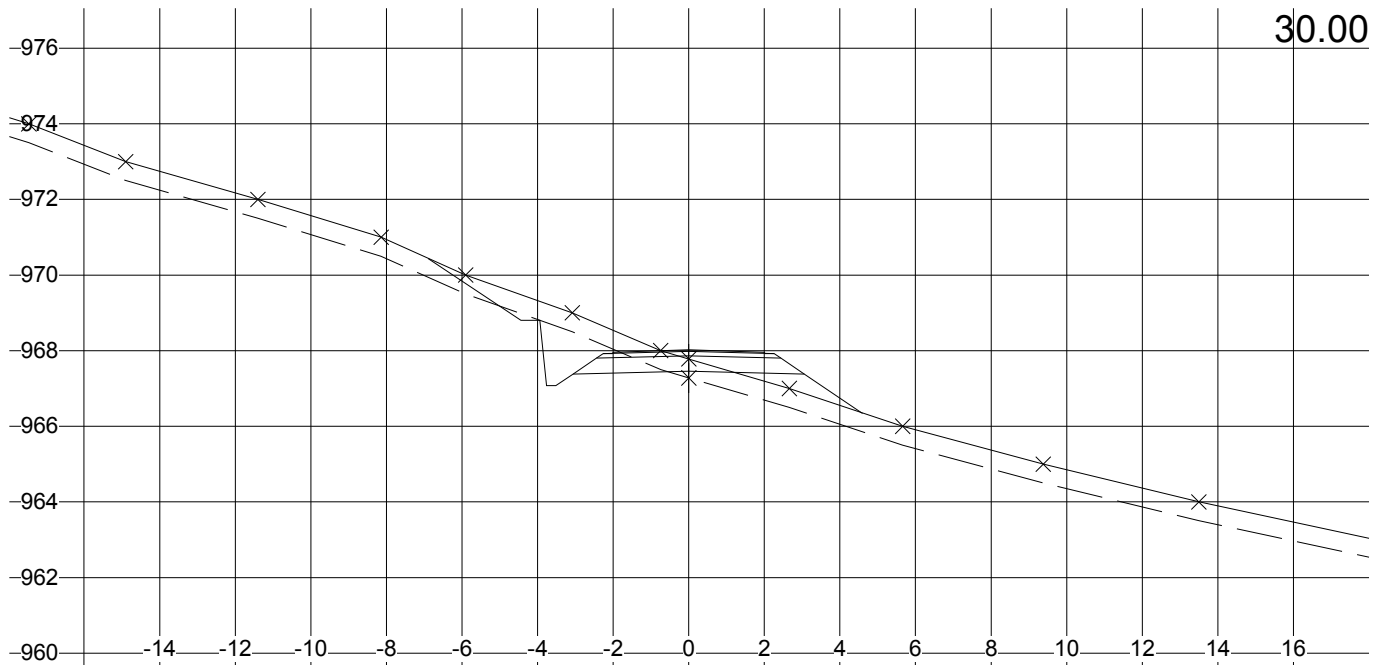
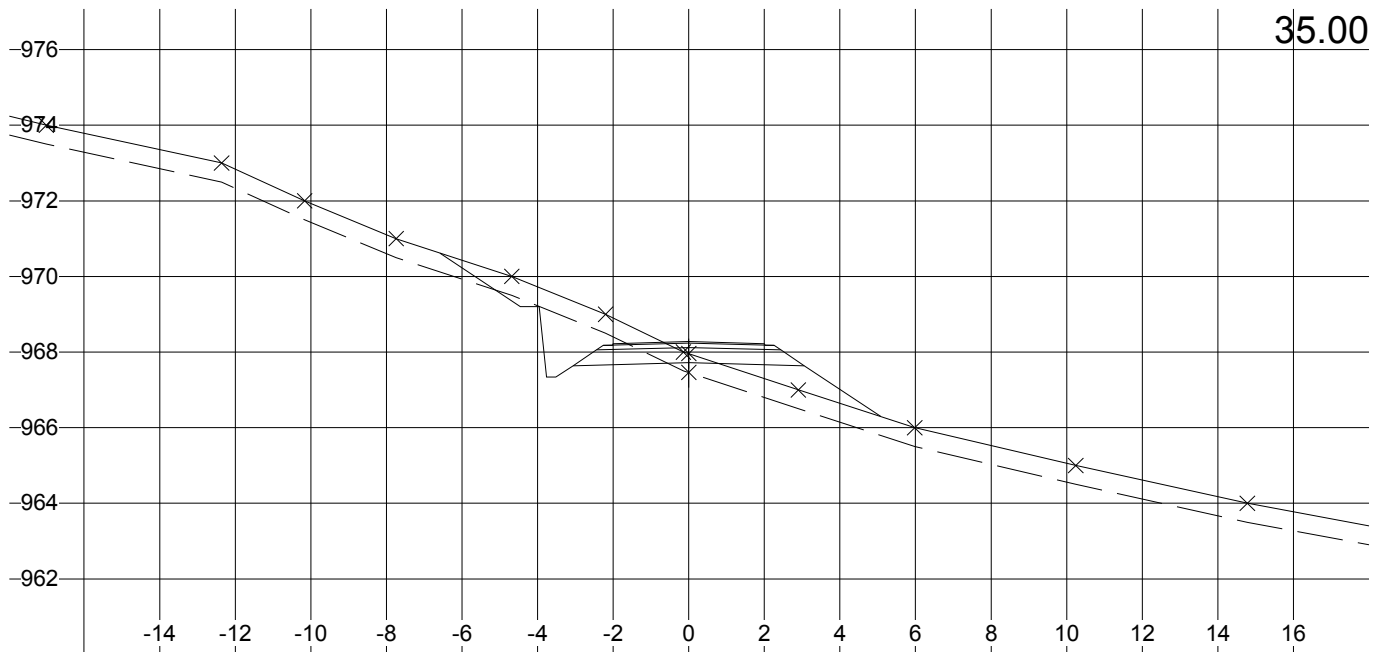

L:\IMA 4.7, Lisens: Plankontoret Hallvard Homme AS, Parsell: Parsell2.psl

Rauland Invest AS Holtarvegen Veg2 Tverrprofil	Tegnet av AST	Saksbehandler
	Sidemannskontr.	Prosjektansvarlig AST
Plankontoret H. Homme AS 4747 Valle Tlf: 37 93 70 00, Fax: 37 93 74 74, E-Post: post@plankontoret.no	Dato 03.12.2009	Målestokk 1: 200
	Prosj.nr. 2219-V2	1: 200
	Tegn.nr. Tp-4	Rev.

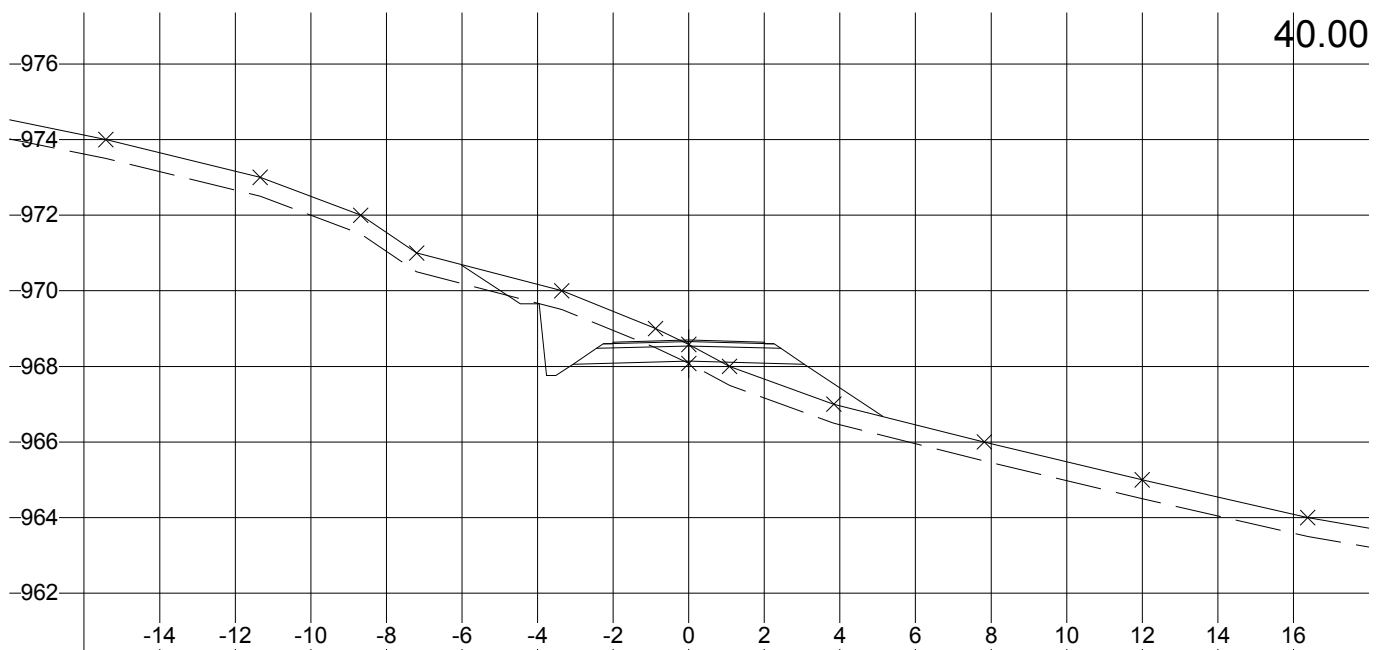
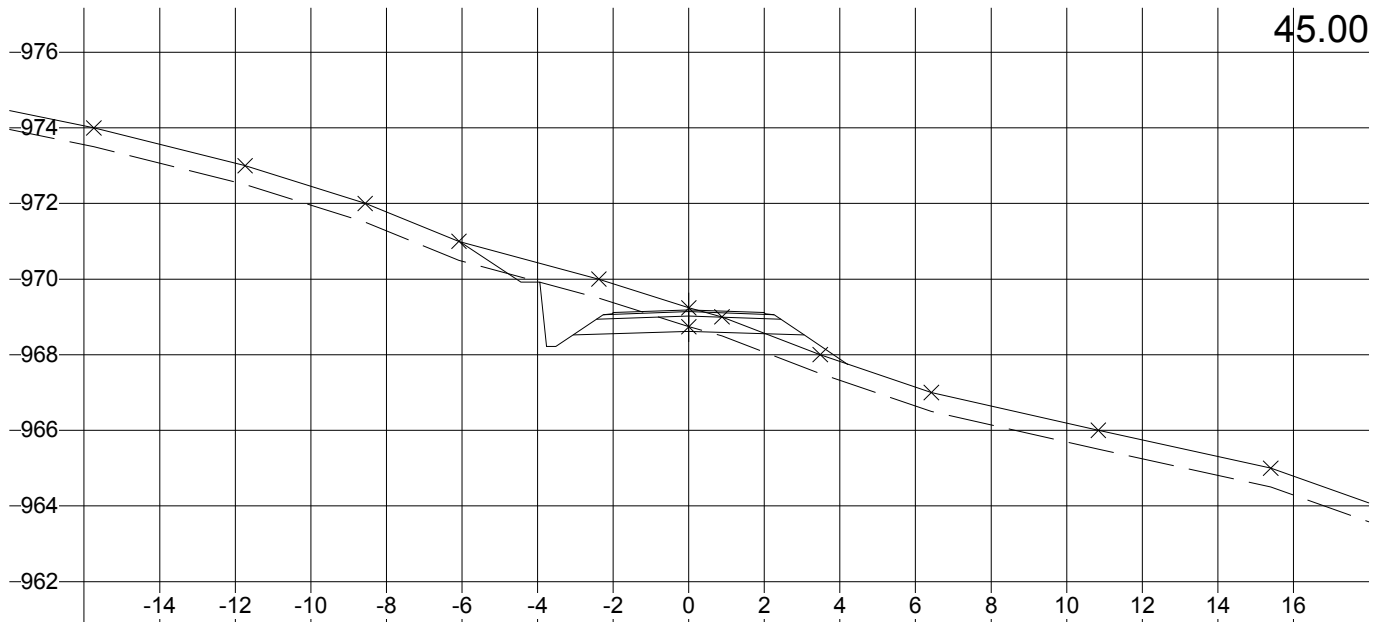

L:\IMA 4.7, Lisens: Plankontoret Hallvard Homme AS, Parsell: Parsell2.psl

Rauland Invest AS Holtarvegen Veg2 Tverrprofil	Tegnet av AST	Saksbehandler
	Sidemannskontr.	Prosjektansvarlig AST
Plankontoret H. Homme AS 4747 Valle Tlf: 37 93 70 00, Fax: 37 93 74 74, E-Post: post@plankontoret.no	Dato 03.12.2009	Målestokk 1: 200
	Prosj.nr. 2219-V2	1: 200
	Tegn.nr. Tp-5	Rev.

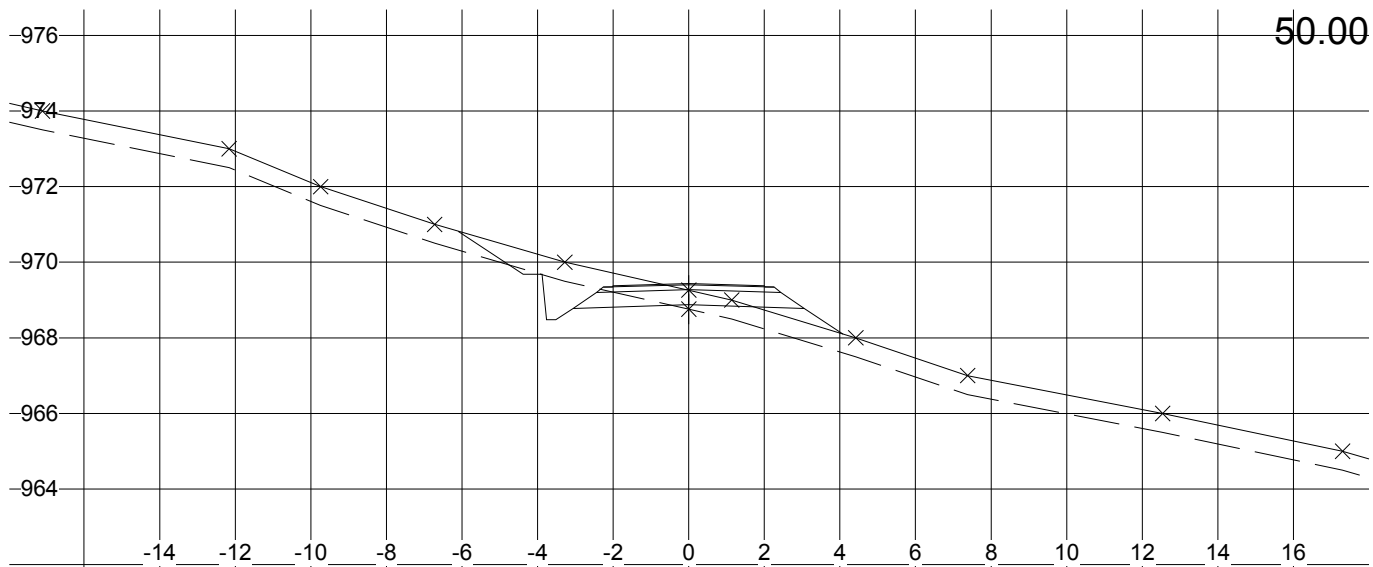
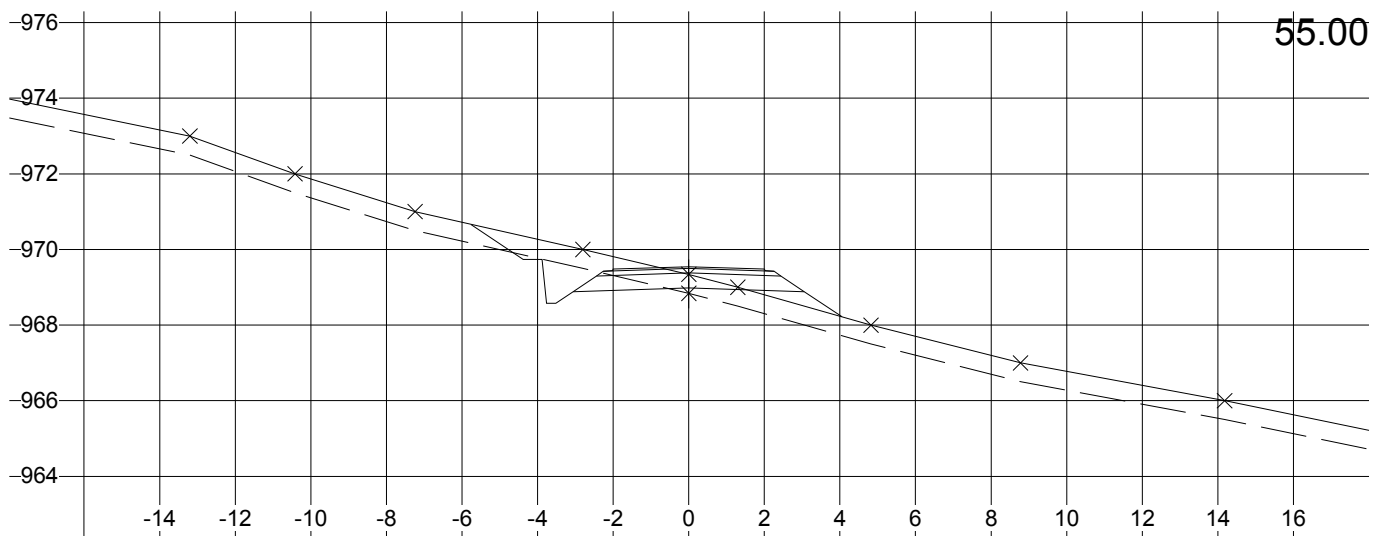

L:\IMA 4.7, Lisens: Plankontoret Hallvard Homme AS, Parsell: Parsell2.psl

Rauland Invest AS Holtarvegen Veg2 Tverrprofil	Tegnet av AST	Saksbehandler
	Sidemannskontr.	Prosjektansvarlig AST
Plankontoret H. Homme AS 4747 Valle Tlf: 37 93 70 00, Fax: 37 93 74 74, E-Post: post@plankontoret.no	Dato 03.12.2009	Målestokk 1: 200
	Prosj.nr. 2219-V2	1: 200
	Tegn.nr. Tp-6	Rev.

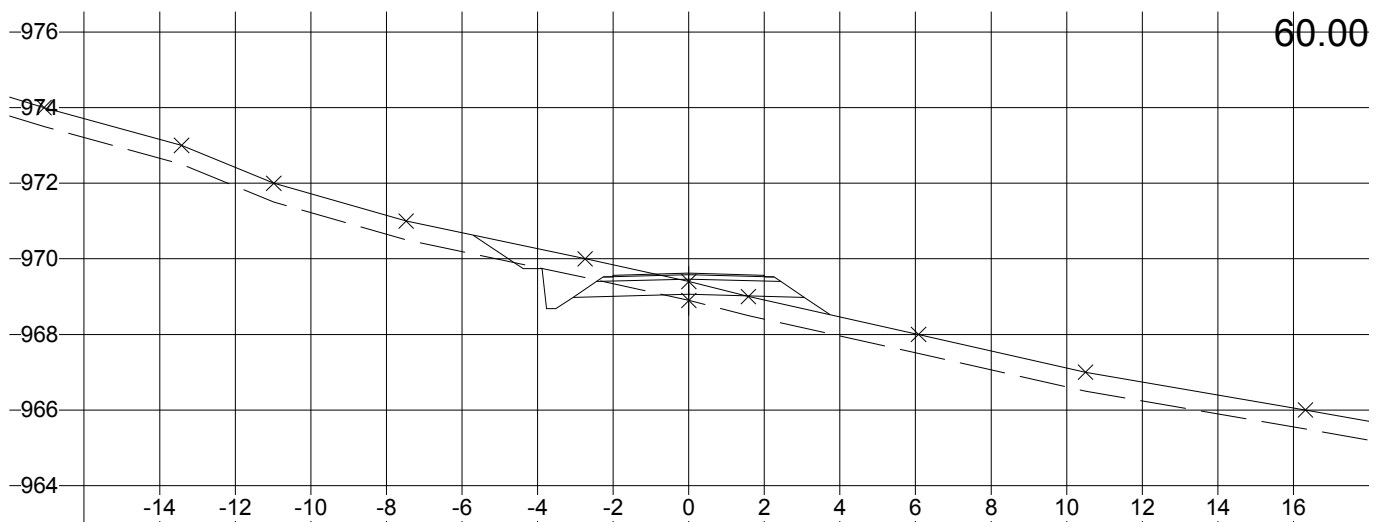
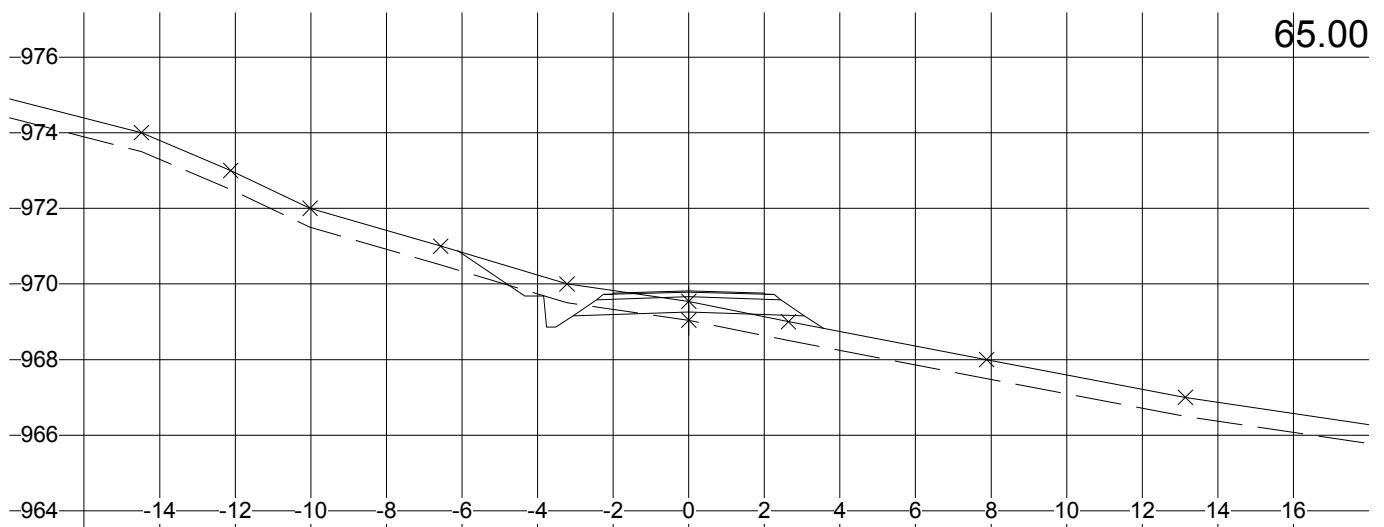

L:\IMA 4.7, Lisens: Plankontoret Hallvard Homme AS, Parsell: Parsell2.psl

Rauland Invest AS Holtarvegen Veg2 Tverrprofil	Tegnet av AST	Saksbehandler
	Sidemannskontr.	Prosjektansvarlig AST
Plankontoret H. Homme AS 4747 Valle Tlf: 37 93 70 00, Fax: 37 93 74 74, E-Post: post@plankontoret.no	Dato 03.12.2009	Målestokk 1: 200
	Prosj.nr. 2219-V2	1: 200
	Tegn.nr. Tp-7	Rev.

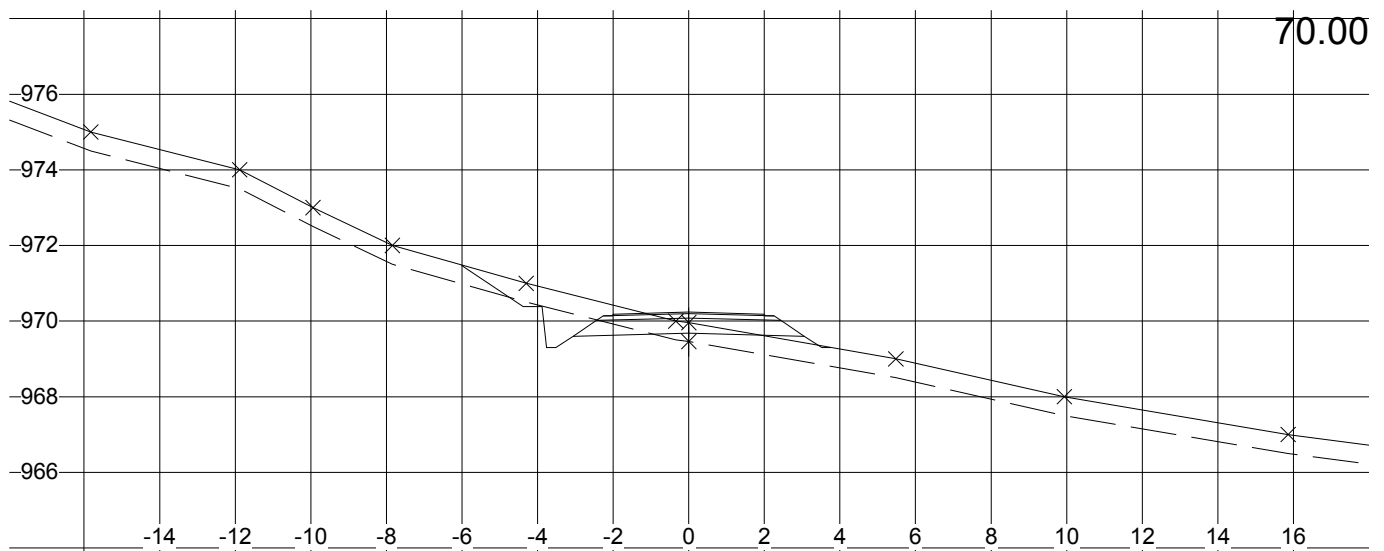
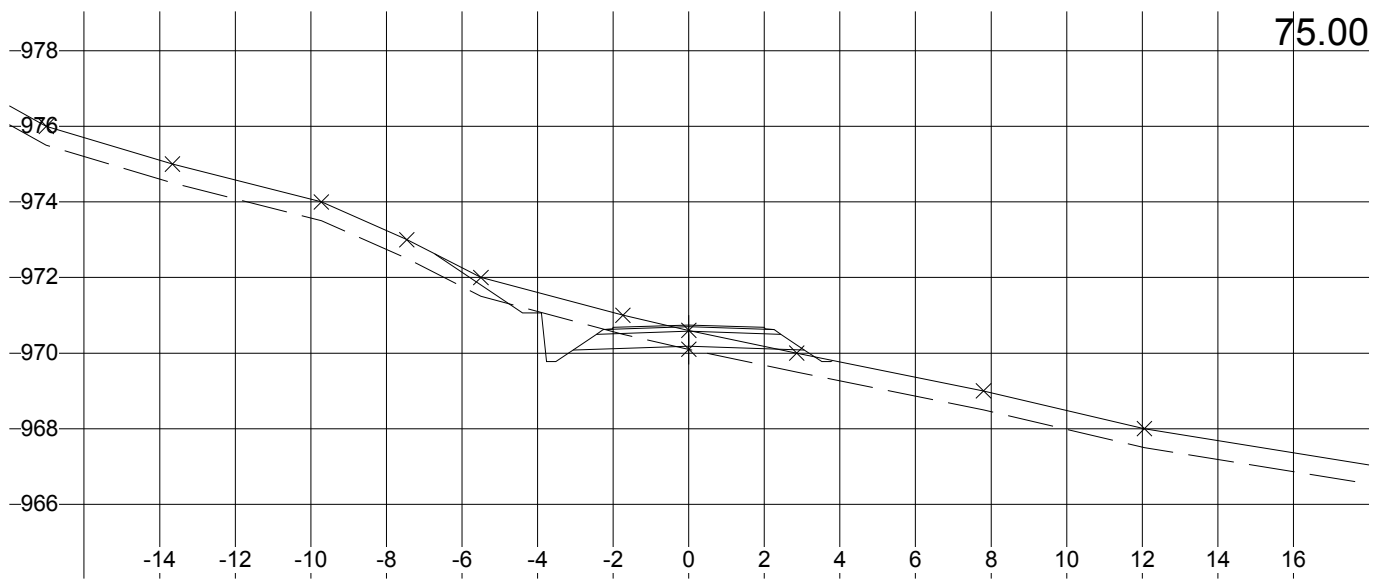

L:\IMA 4.7, Lisens: Plankontoret Hallvard Homme AS, Parsell: Parsell2.psl

Rauland Invest AS Holtarvegen Veg2 Tverrprofil	Tegnet av AST	Saksbehandler
	Sidemannskontr.	Prosjektansvarlig AST
Plankontoret H. Homme AS 4747 Valle Tlf: 37 93 70 00, Fax: 37 93 74 74, E-Post: post@plankontoret.no	Dato 03.12.2009	Målestokk 1: 200
	Prosj.nr. 2219-V2	1: 200
	Tegn.nr. Tp-8	Rev.

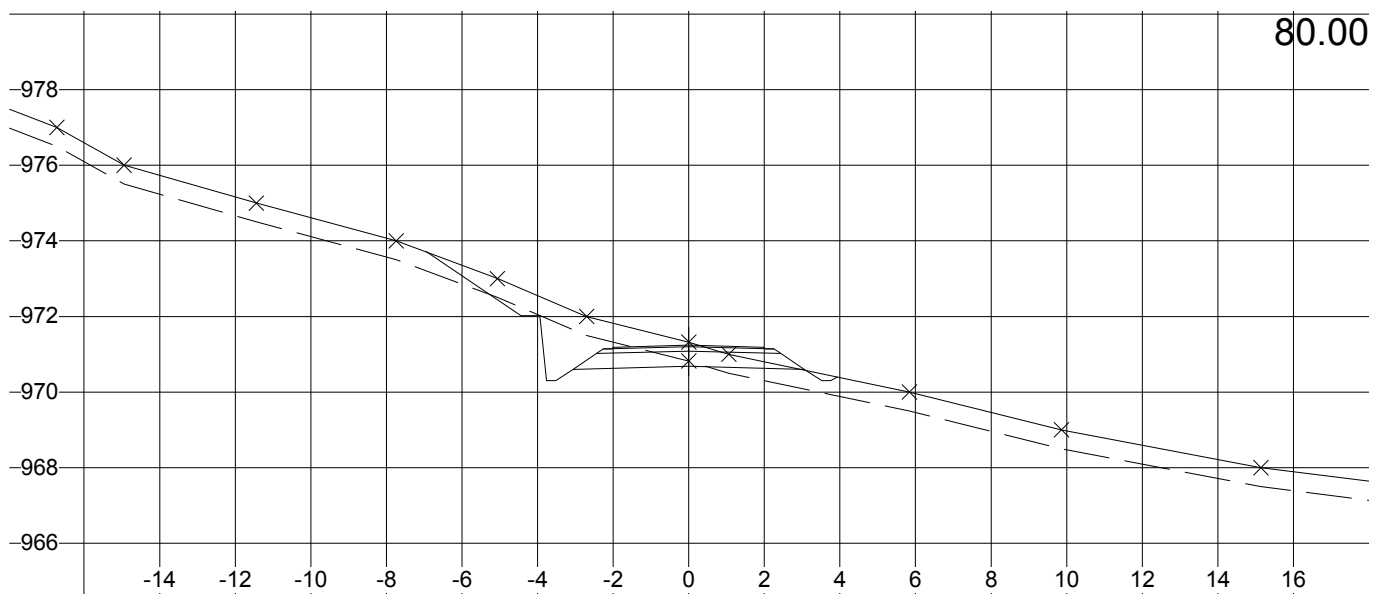
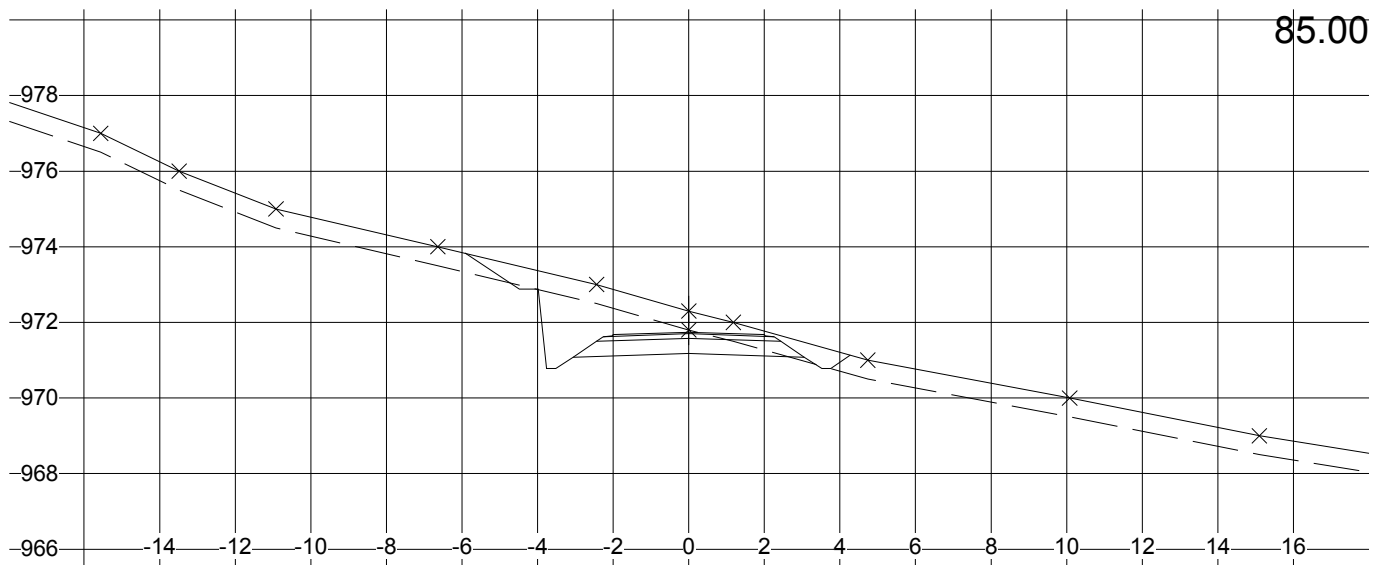

Rauland Invest AS Holtarvegen Veg2 Tverrprofil	Tegnet av AST	Saksbehandler
	Sidemannskontr.	Prosjektansvarlig AST
	Dato 03.12.2009	Målestokk 1: 200
	Prosj.nr. 2219-V2	1: 200
Plankontoret H. Homme AS 4747 Valle Tlf: 37 93 70 00, Fax: 37 93 74 74, E-Post: post@plankontoret.no	Tegn.nr. Tp-9	Rev.

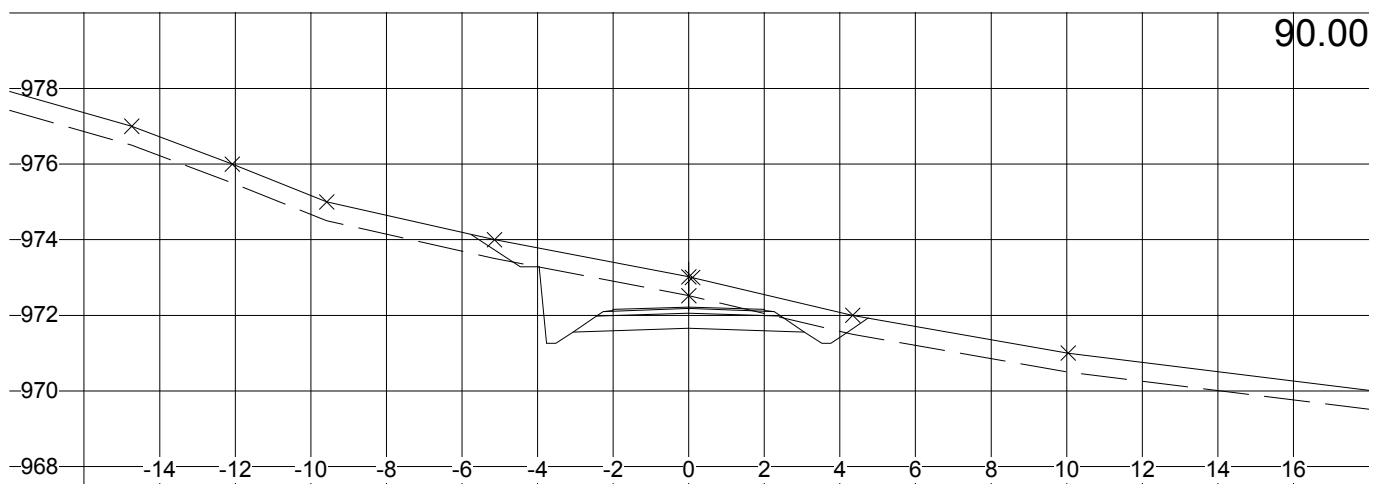
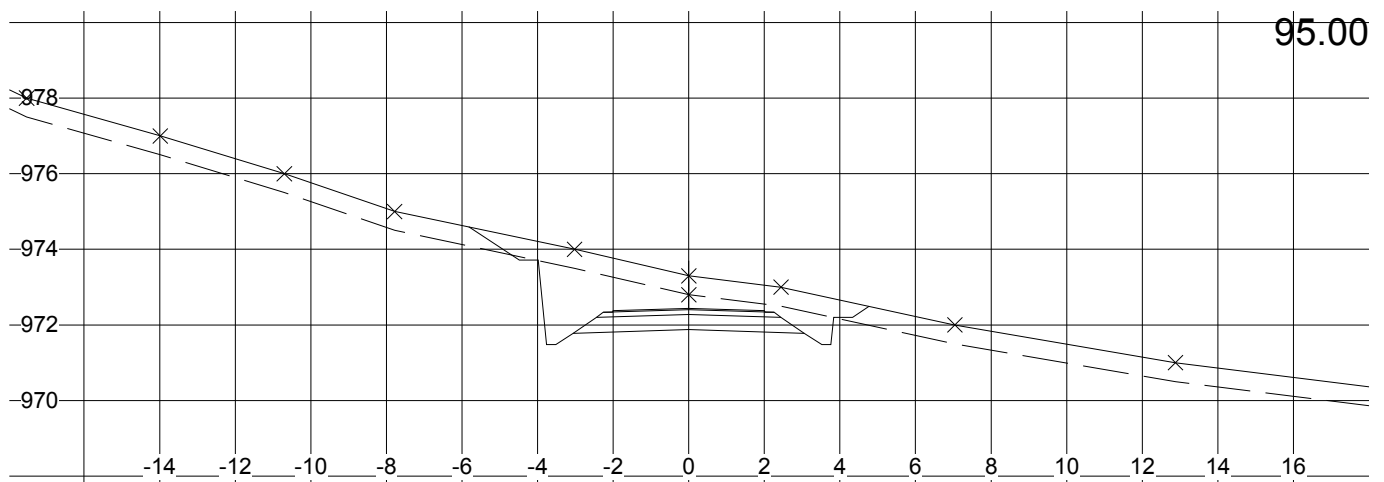
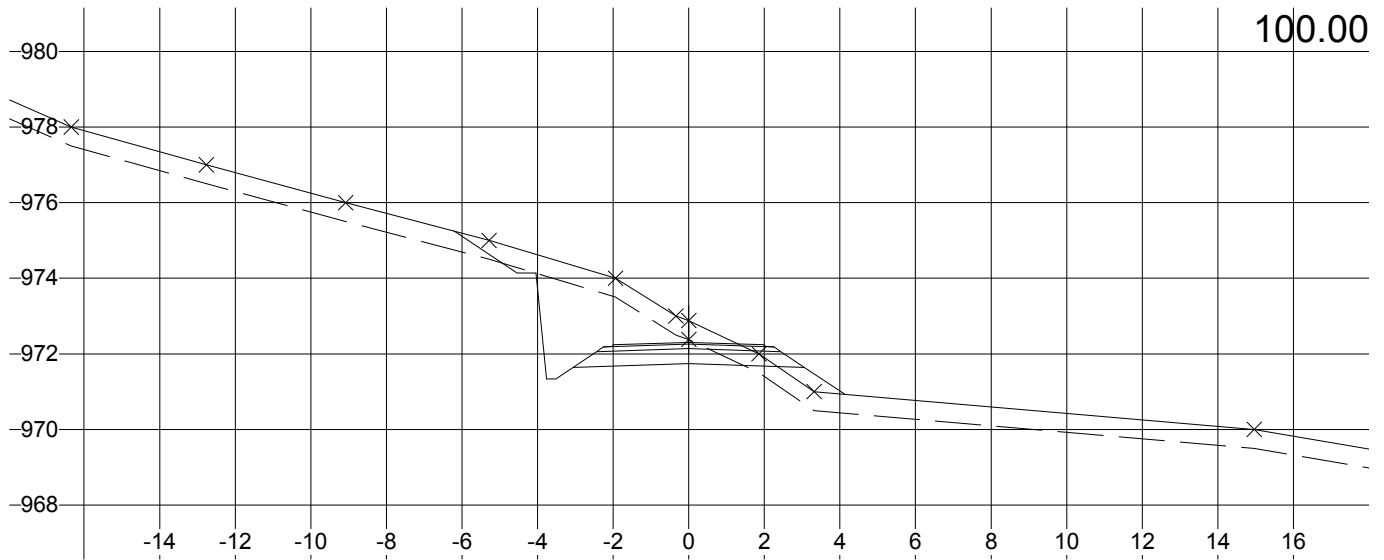

LIMA 4.7, Lisens: Plankontoret Hallvard Homme AS, Parsell: Parsell2.psl

Rauland Invest AS Holtarvegen Veg2 Tverrprofil	Tegnet av AST	Saksbehandler
	Sidemannskonstr.	Prosjektansvarlig AST
	Dato 03.12.2009	Målestokk 1: 200
	Prosj.nr. 2219-V2	1: 200
Plankontoret H. Homme AS 4747 Valle Tlf: 37 93 70 00, Fax: 37 93 74 74, E-Post: post@plankontoret.no	Tegn.nr. Tp-10	Rev.

110.00

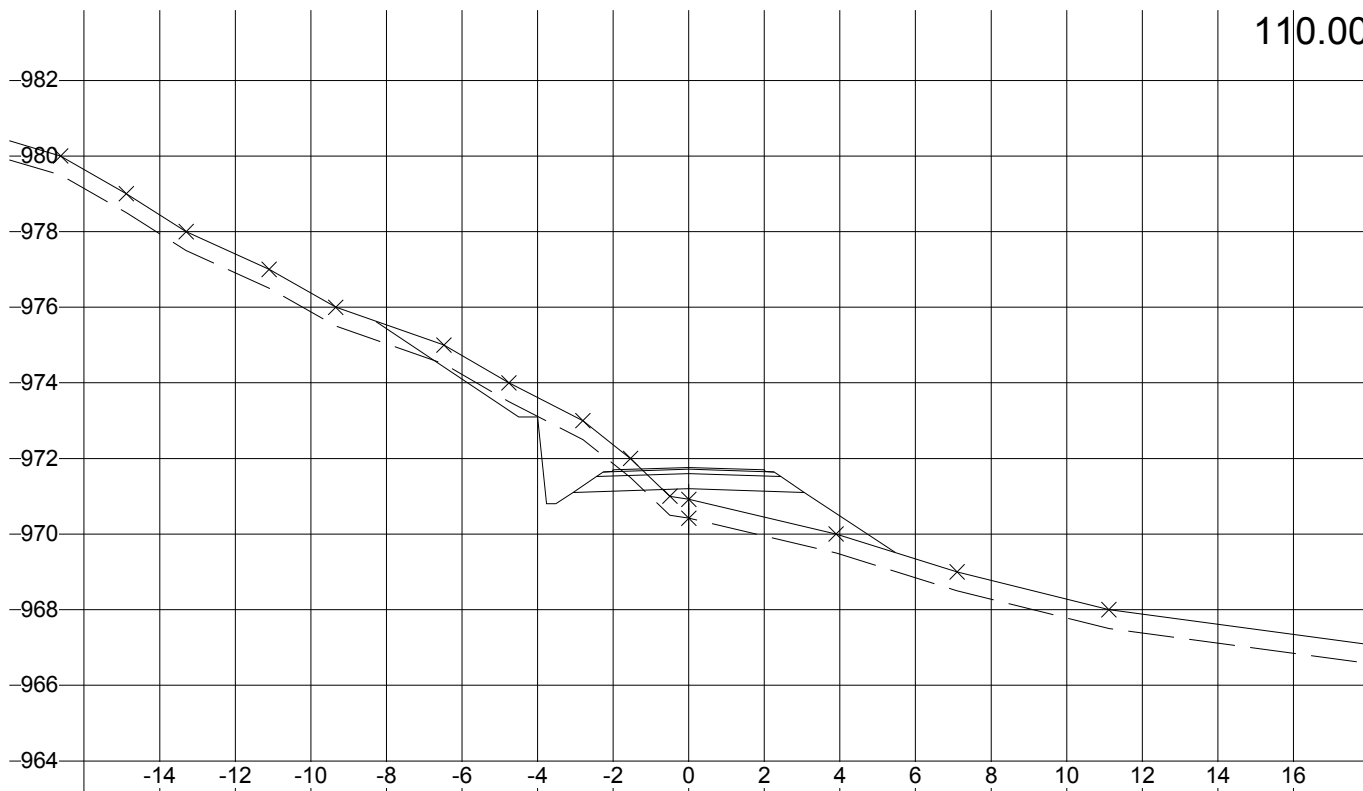

105.00

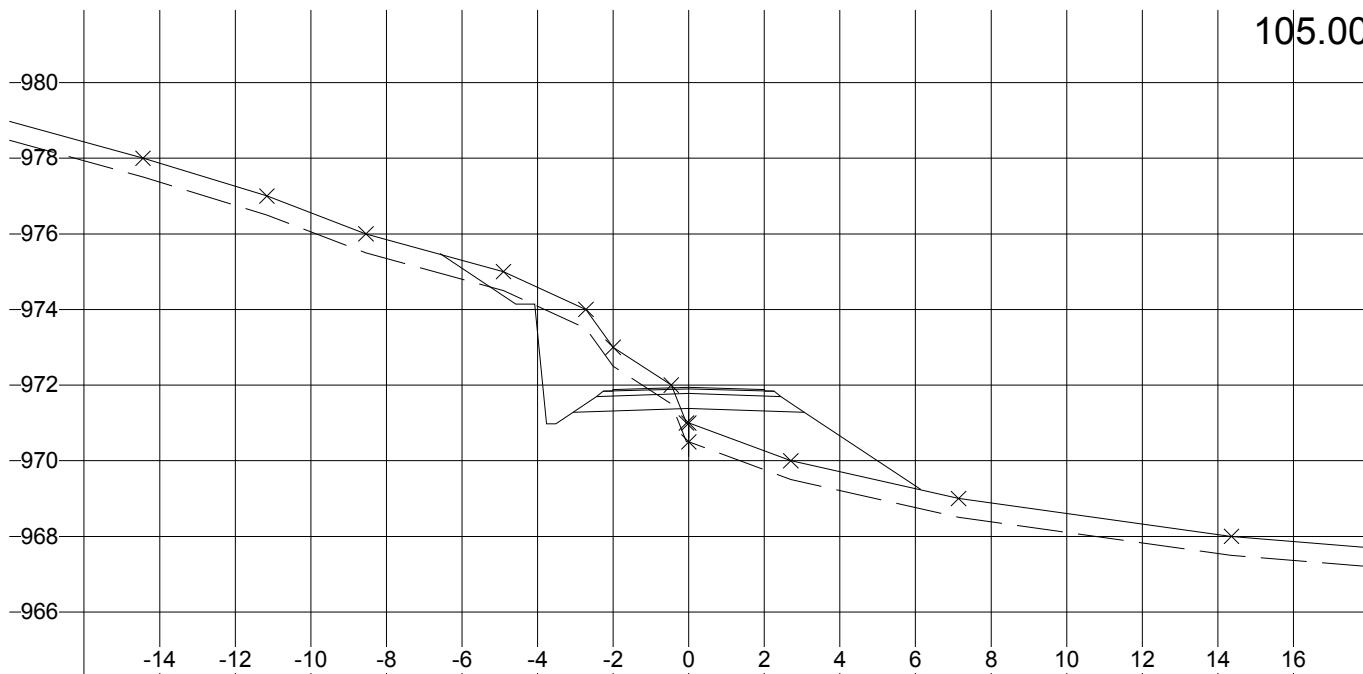

L:\IMA 4.7, Lisens: Plankontoret Hallvard Homme AS, Parsell: Parsell2.psl

Rauland Invest AS Holtarvegen Veg2 Tverrprofil	Tegnet av AST	Saksbehandler
	Sidemannskontr.	Prosjektansvarlig AST
	Dato 03.12.2009	Målestokk 1: 200
	Prosj.nr. 2219-V2	1: 200
Plankontoret H. Homme AS 4747 Valle Tlf: 37 93 70 00, Fax: 37 93 74 74, E-Post: post@plankontoret.no	Tegn.nr. Tp-11	Rev.

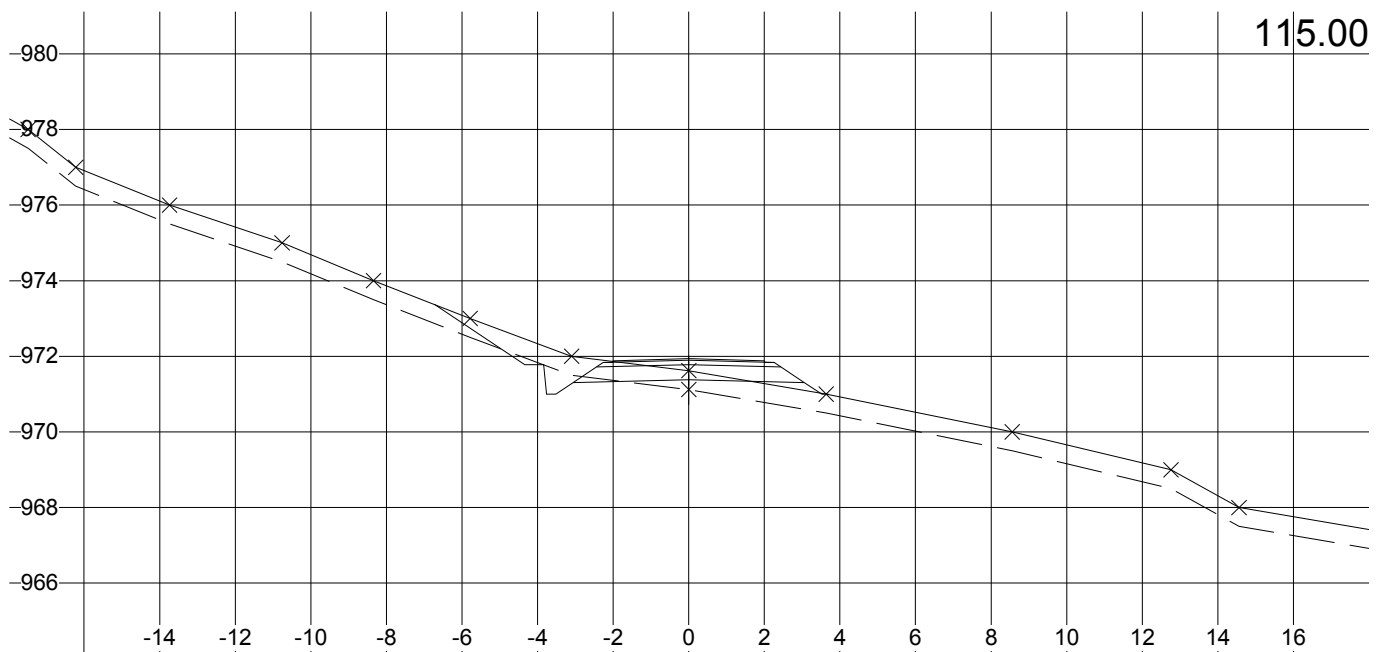
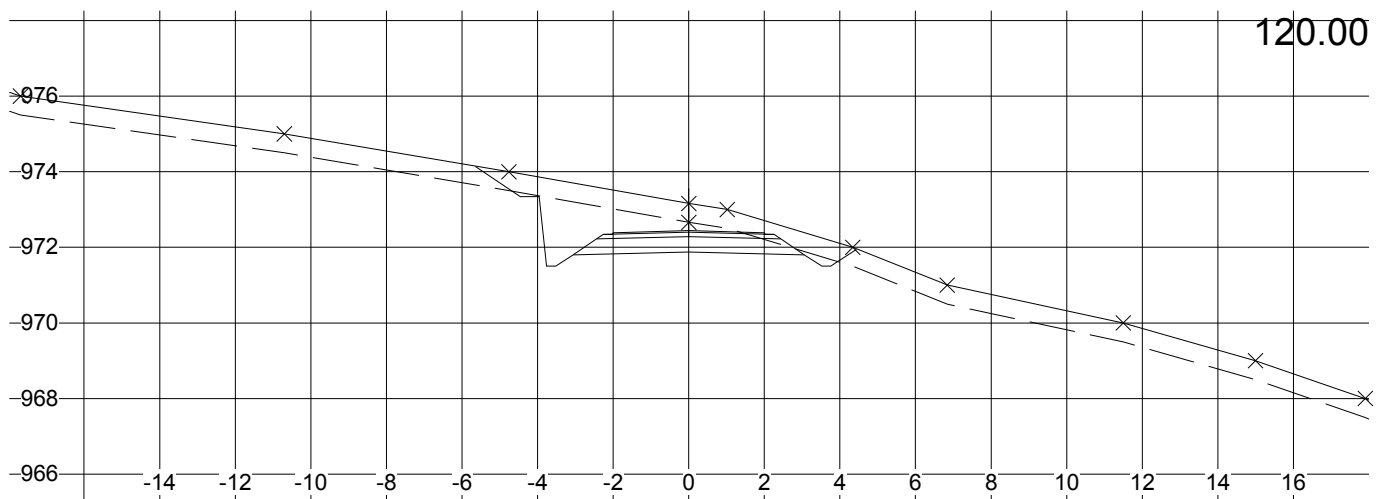

L:\IMA 4.7, Lisens: Plankontoret Hallvard Homme AS, Parsell: Parsell2.psl

Rauland Invest AS Holtarvegen Veg2 Tverrprofil	Tegnet av AST	Saksbehandler
	Sidemannskontr.	Prosjektansvarlig AST
Plankontoret H. Homme AS 4747 Valle Tlf: 37 93 70 00, Fax: 37 93 74 74, E-Post: post@plankontoret.no	Dato 03.12.2009	Målestokk 1: 200
	Prosj.nr. 2219-V2	1: 200
	Tegn.nr. Tp-12	Rev.

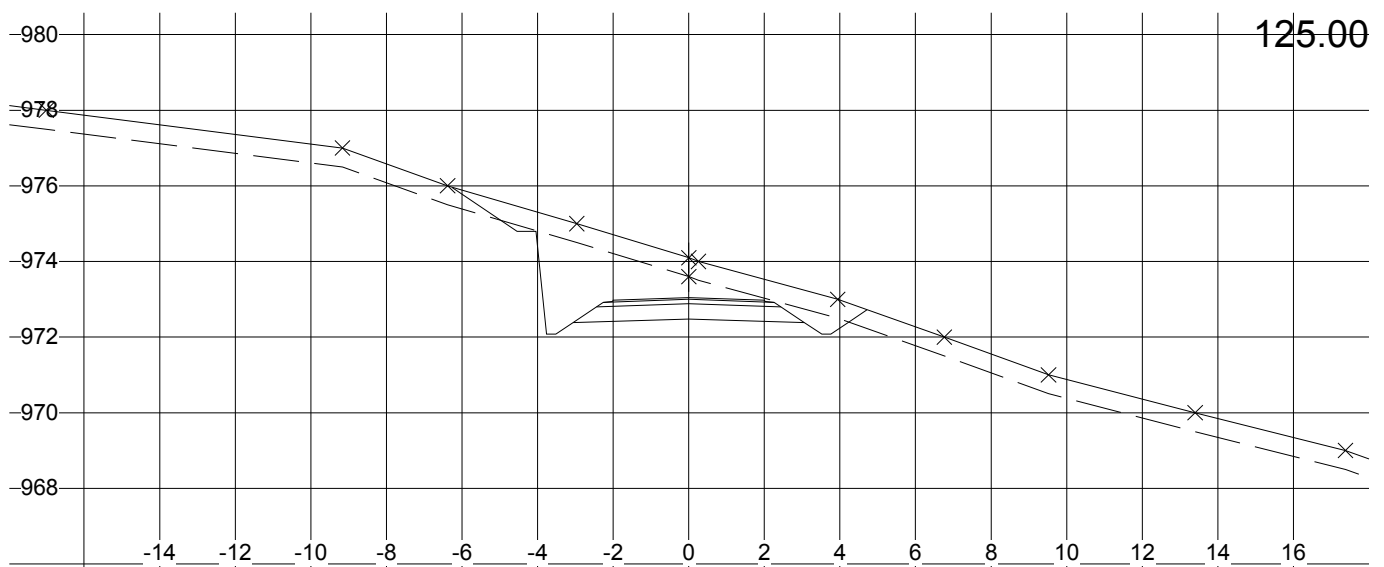
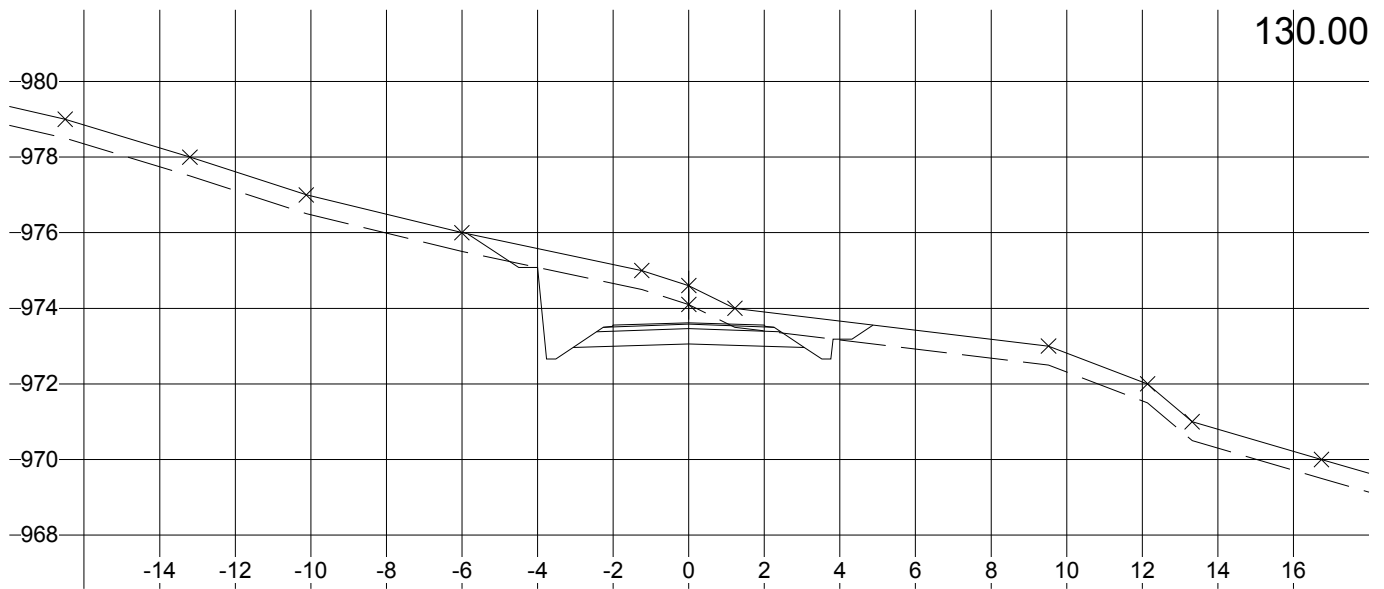

Rauland Invest AS Holtarvegen Veg2 Tverrprofil	Tegnet av AST	Saksbehandler
	Sidemannskontr.	Prosjektansvarlig AST
Plankontoret H. Homme AS 4747 Valle Tlf: 37 93 70 00, Fax: 37 93 74 74, E-Post: post@plankontoret.no	Dato 03.12.2009	Målestokk 1: 200
	Prosj.nr. 2219-V2	1: 200
	Tegn.nr. Tp-13	Rev.

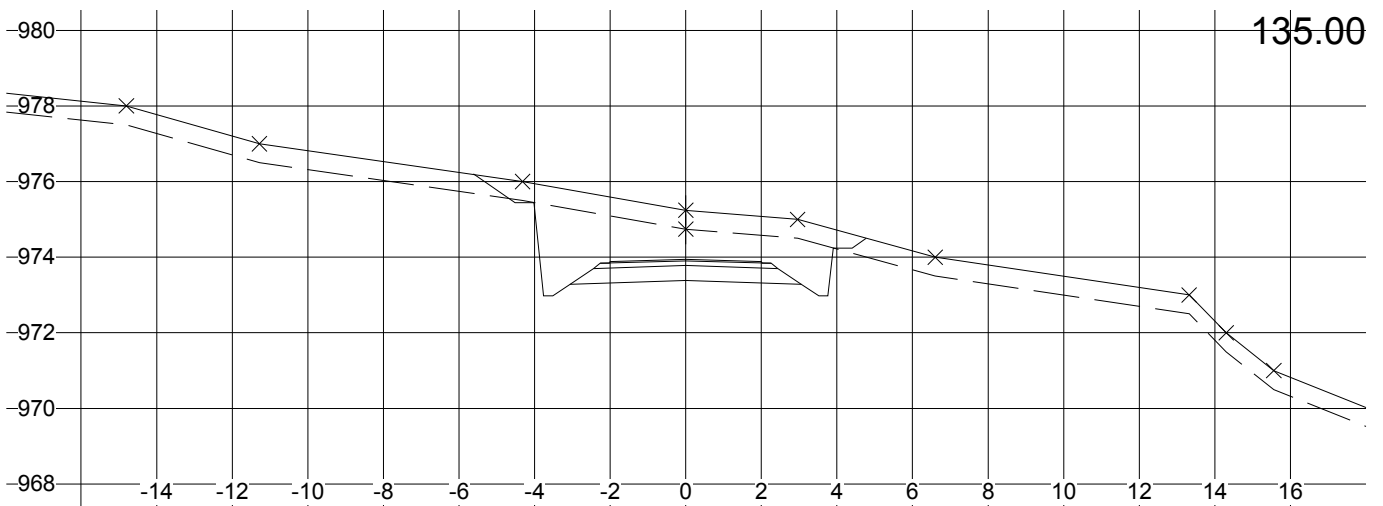
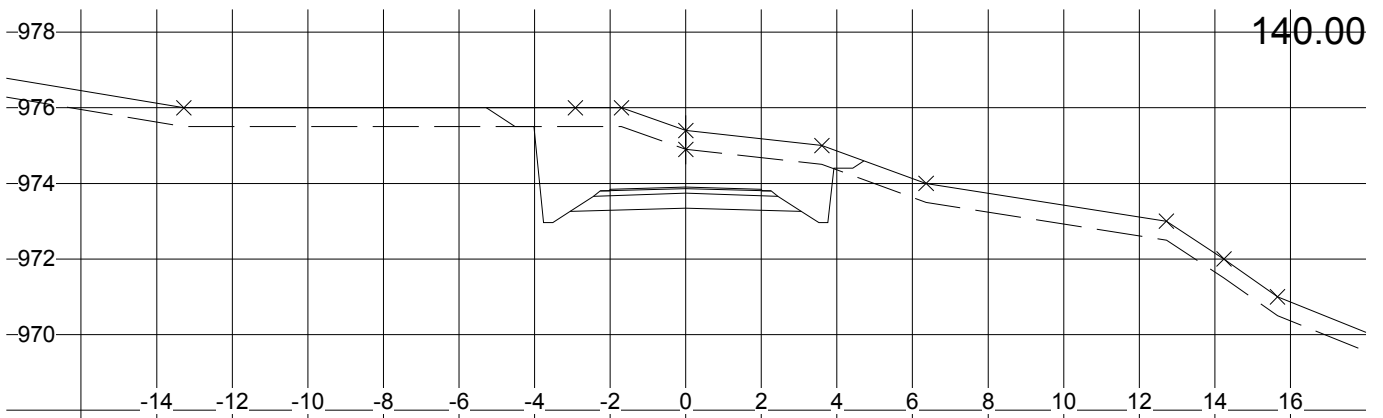
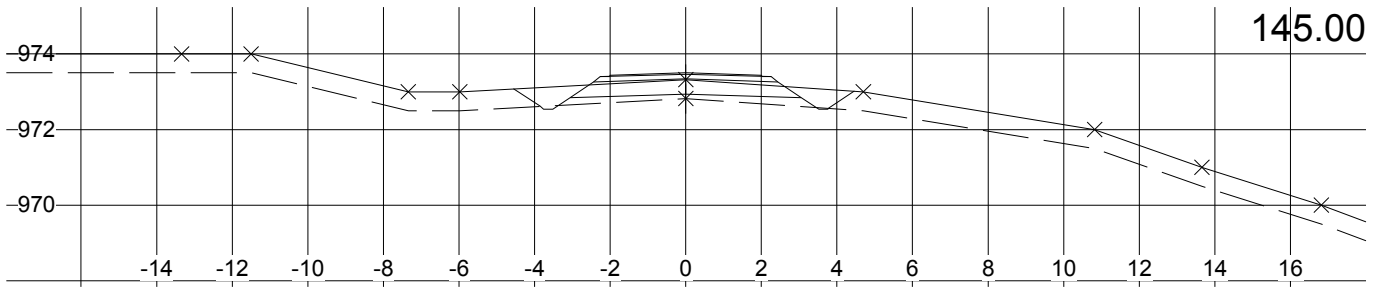

L:\IMA 4.7, Lisens: Plankontoret Hallvard Homme AS, Parsell: Parsell2.psl

Rauland Invest AS Holtarvegen Veg2 Tverrprofil	Tegnet av AST	Saksbehandler
	Sidemannskontr.	Prosjektansvarlig AST
Plankontoret H. Homme AS 4747 Valle Tlf: 37 93 70 00, Fax: 37 93 74 74, E-Post: post@plankontoret.no	Dato 03.12.2009	Målestokk 1: 200
	Prosj.nr. 2219-V2	1: 200
	Tegn.nr. Tp-14	Rev.

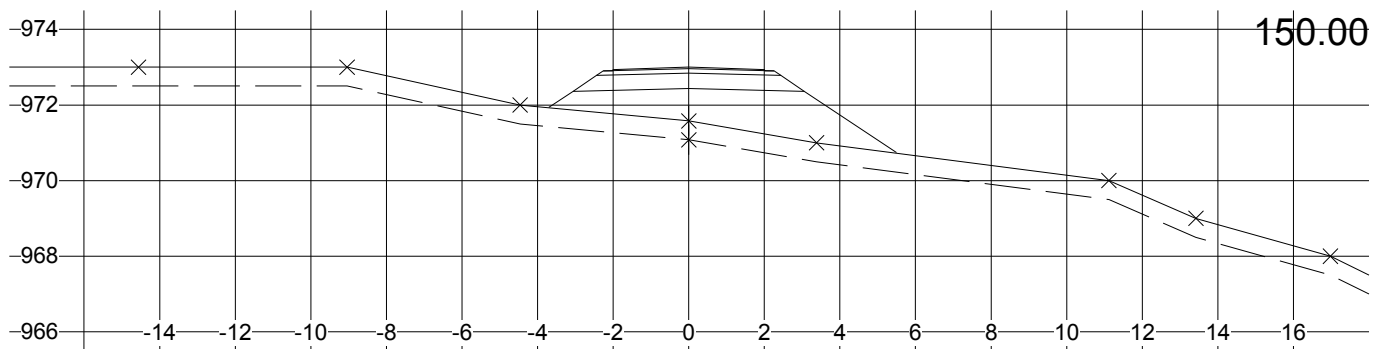
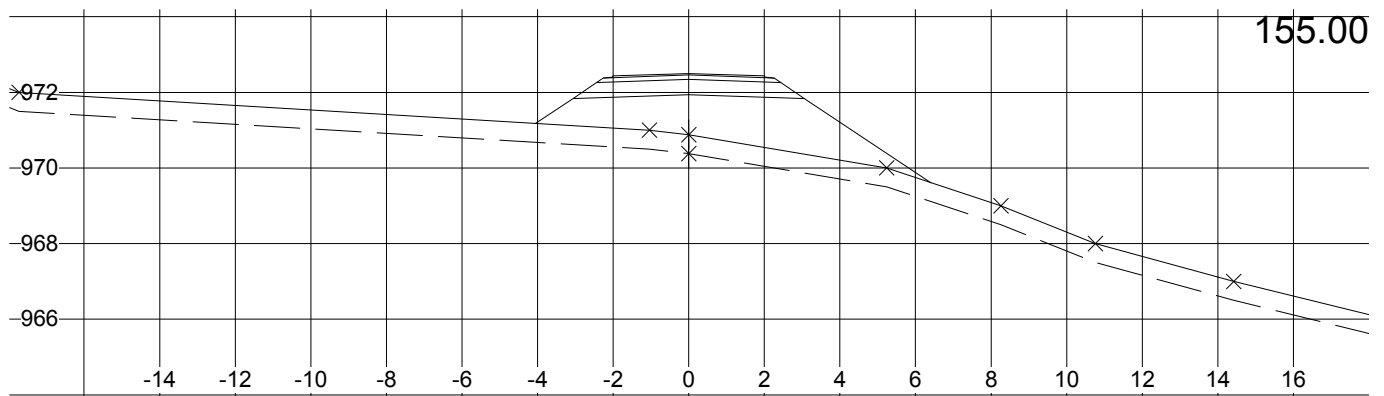
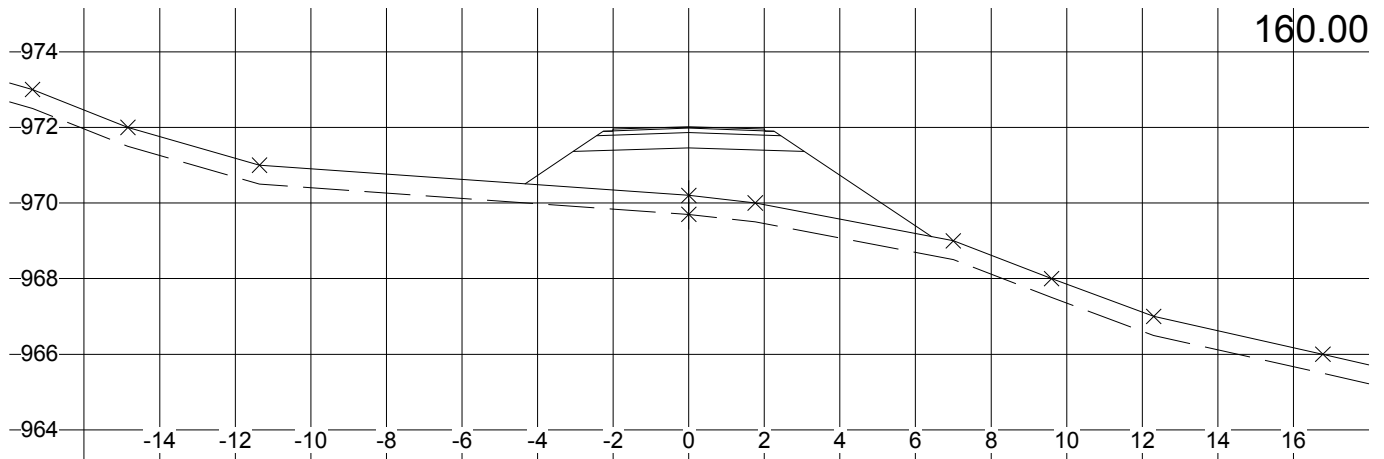

Rauland Invest AS Holtarvegen Veg2 Tverrprofil	Tegnet av AST	Saksbehandler
	Sidemannskontr.	Prosjektansvarlig AST
Plankontoret H. Homme AS 4747 Valle Tlf: 37 93 70 00, Fax: 37 93 74 74, E-Post: post@plankontoret.no	Dato 03.12.2009	Målestokk 1: 200
	Prosj.nr. 2219-V2	1: 200
	Tegn.nr. Tp-15	Rev.

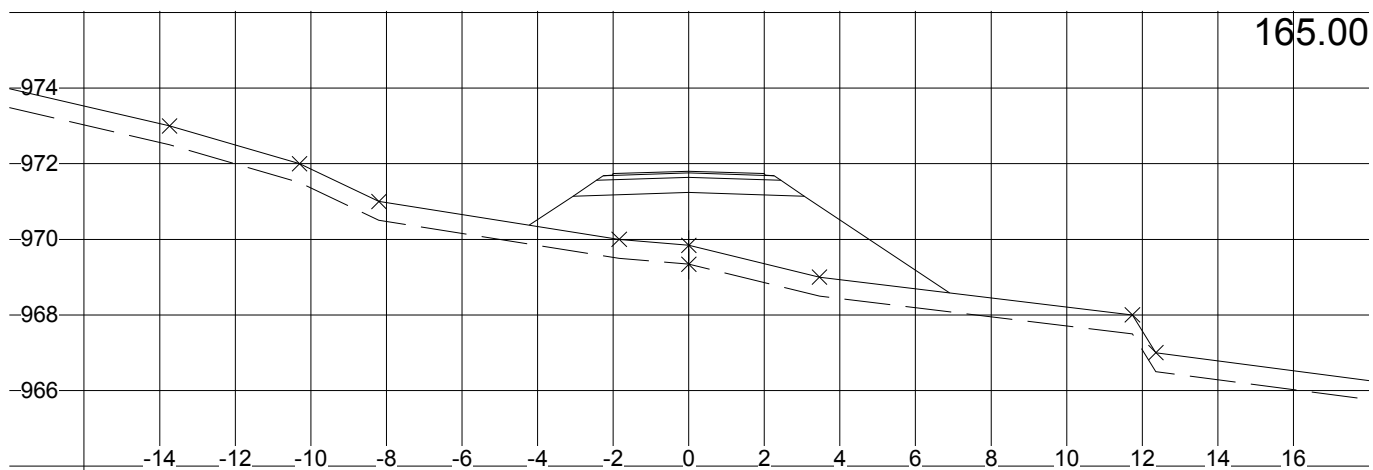
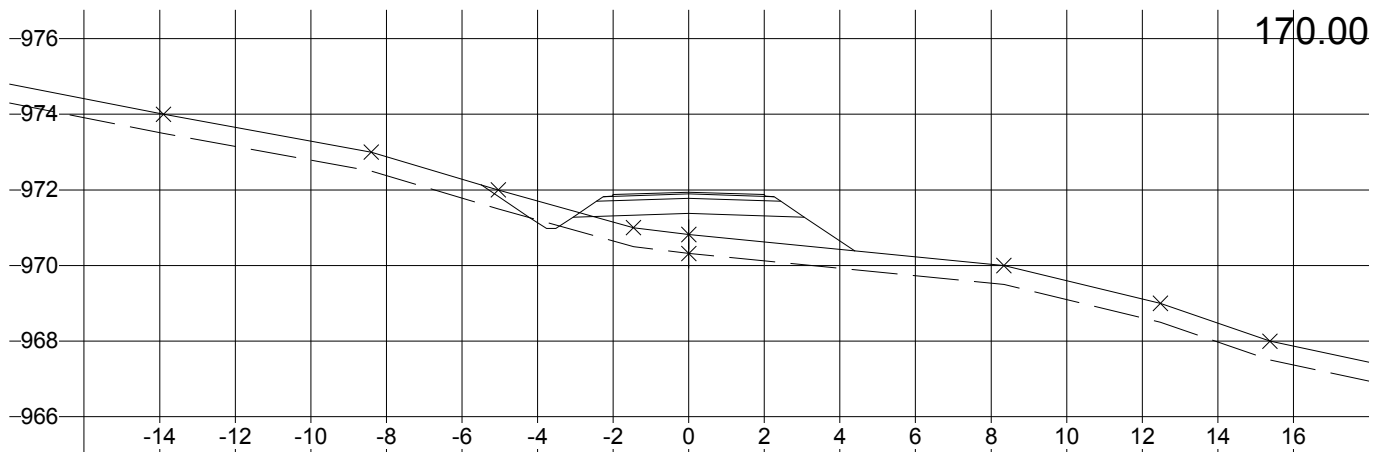
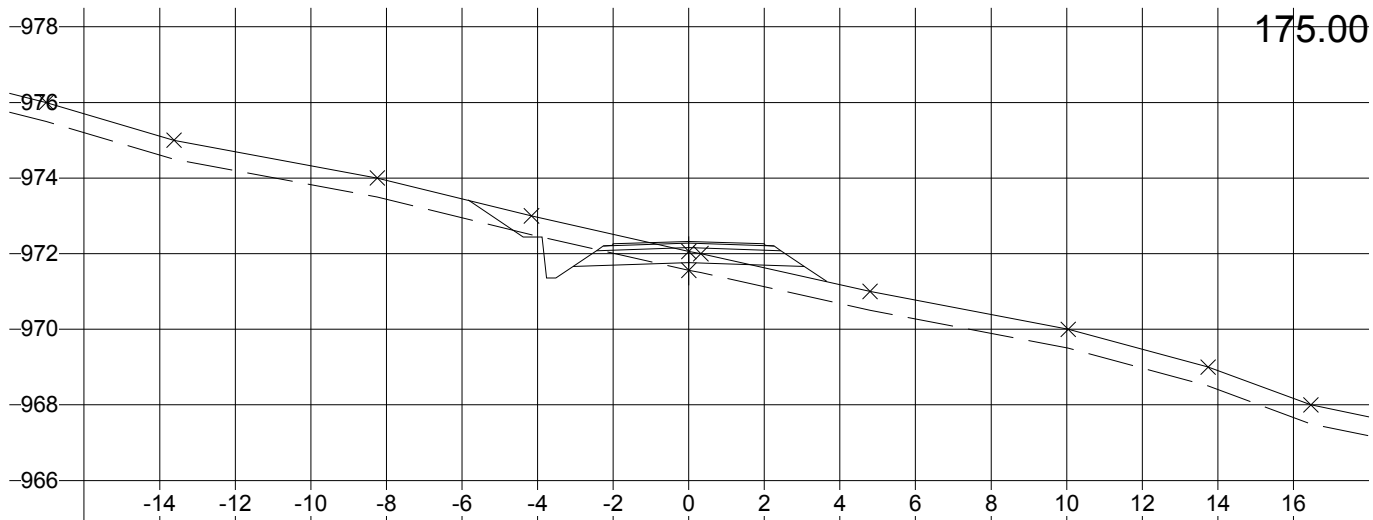

LIMA 4.7, Lisens: Plankontoret Hallvard Homme AS, Parsell: Parsell2.psl

Rauland Invest AS Holtarvegen Veg2 Tverrprofil	Tegnet av AST	Saksbehandler
	Sidemannkontr.	Prosjektansvarlig AST
	Dato 03.12.2009	Målestokk 1: 200
	Prosj.nr. 2219-V2	1: 200
Plankontoret H. Homme AS 4747 Valle Tlf: 37 93 70 00, Fax: 37 93 74 74, E-Post: post@plankontoret.no	Tegn.nr. Tp-16	Rev.

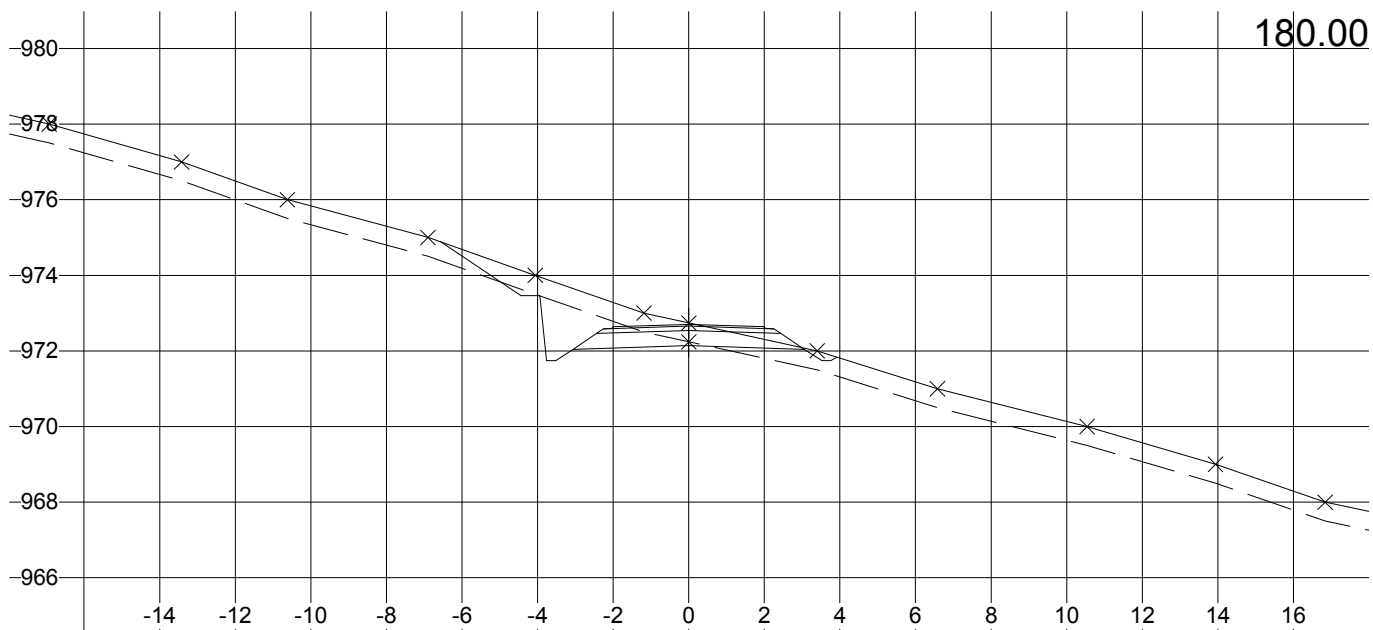
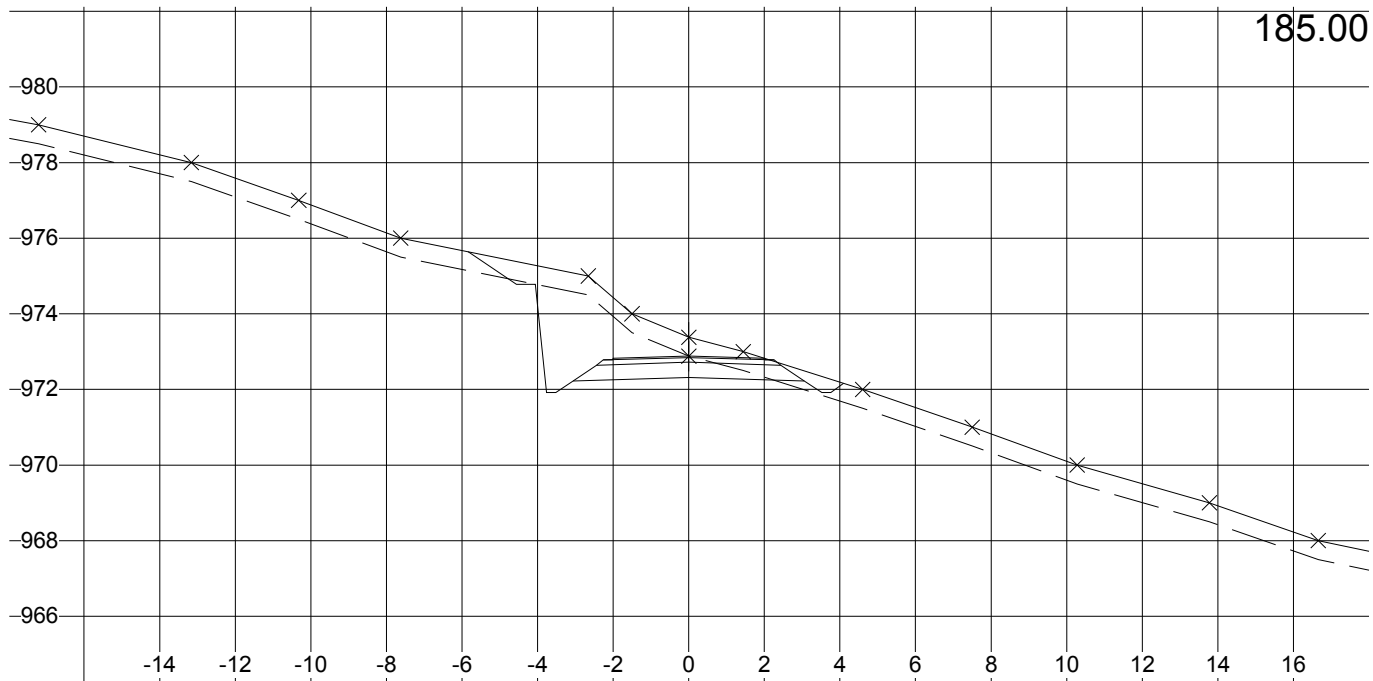

L:\IMA 4.7, Lisens: Plankontoret Hallvard Homme AS, Parsell: Parsell2.ps1

Rauland Invest AS Holtarvegen Veg2 Tverrprofil	Tegnet av AST	Saksbehandler
	Sidemannskontr.	Prosjektansvarlig AST
Plankontoret H. Homme AS 4747 Valle Tlf: 37 93 70 00, Fax: 37 93 74 74, E-Post: post@plankontoret.no	Dato 03.12.2009	Målestokk 1: 200
	Prosj.nr. 2219-V2	1: 200
	Tegn.nr. Tp-17	Rev.

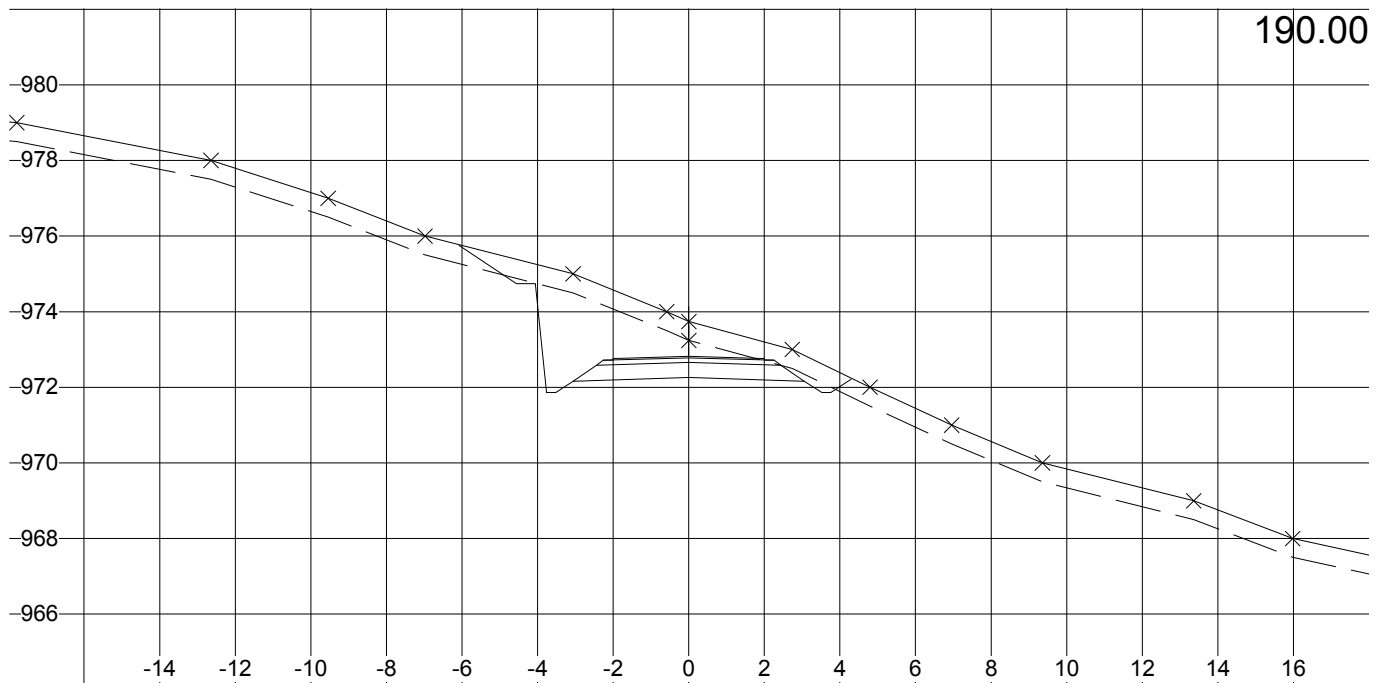
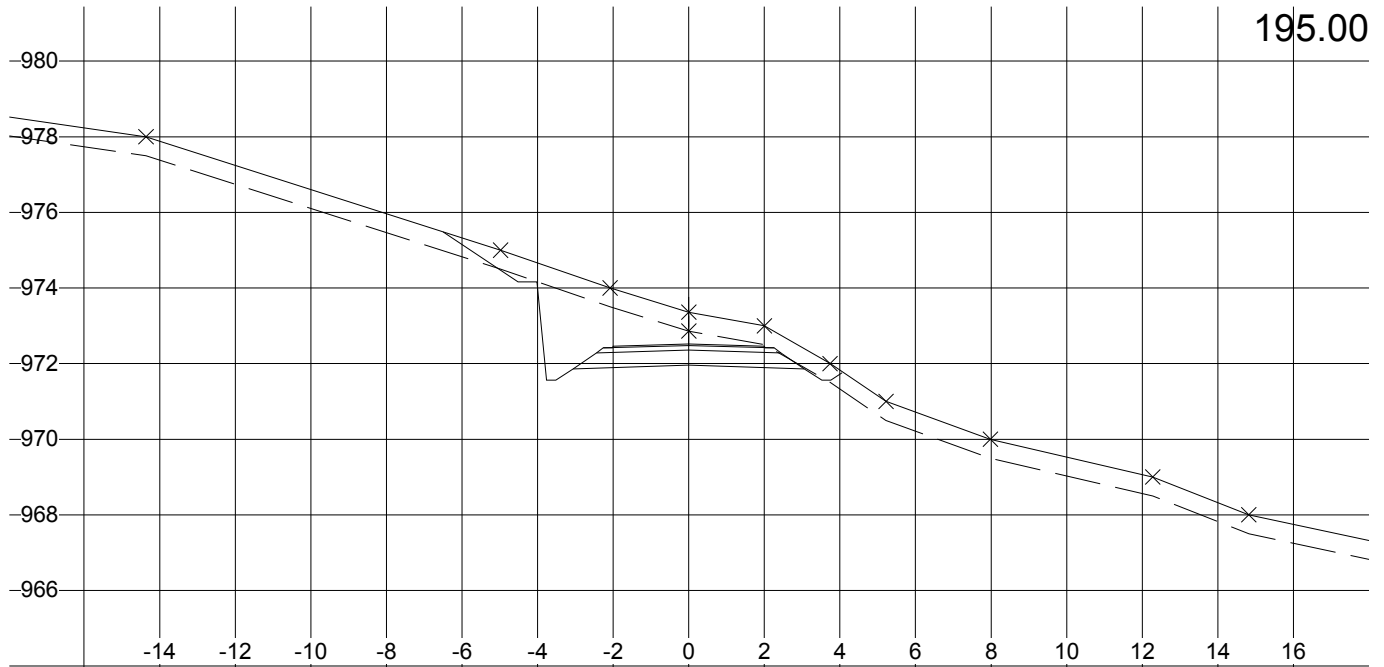

L:\IMA 4.7, Lisens: Plankontoret Hallvard Homme AS, Parsell: Parsell2.psl

Rauland Invest AS Holtarvegen Veg2 Tverrprofil	Tegnet av AST	Saksbehandler
	Sidemannskontr.	Prosjektansvarlig AST
Plankontoret H. Homme AS 4747 Valle Tlf: 37 93 70 00, Fax: 37 93 74 74, E-Post: post@plankontoret.no	Dato 03.12.2009	Målestokk 1: 200
	Prosj.nr. 2219-V2	1: 200
	Tegn.nr. Tp-18	Rev.

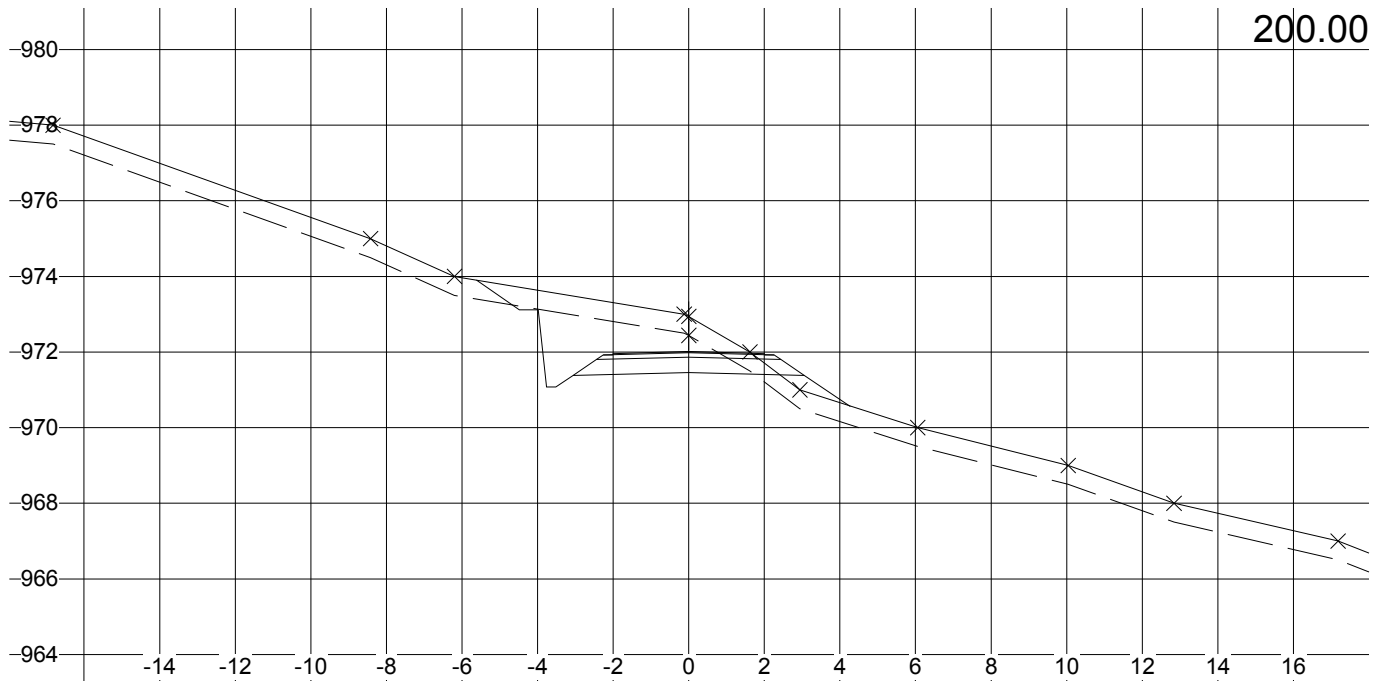
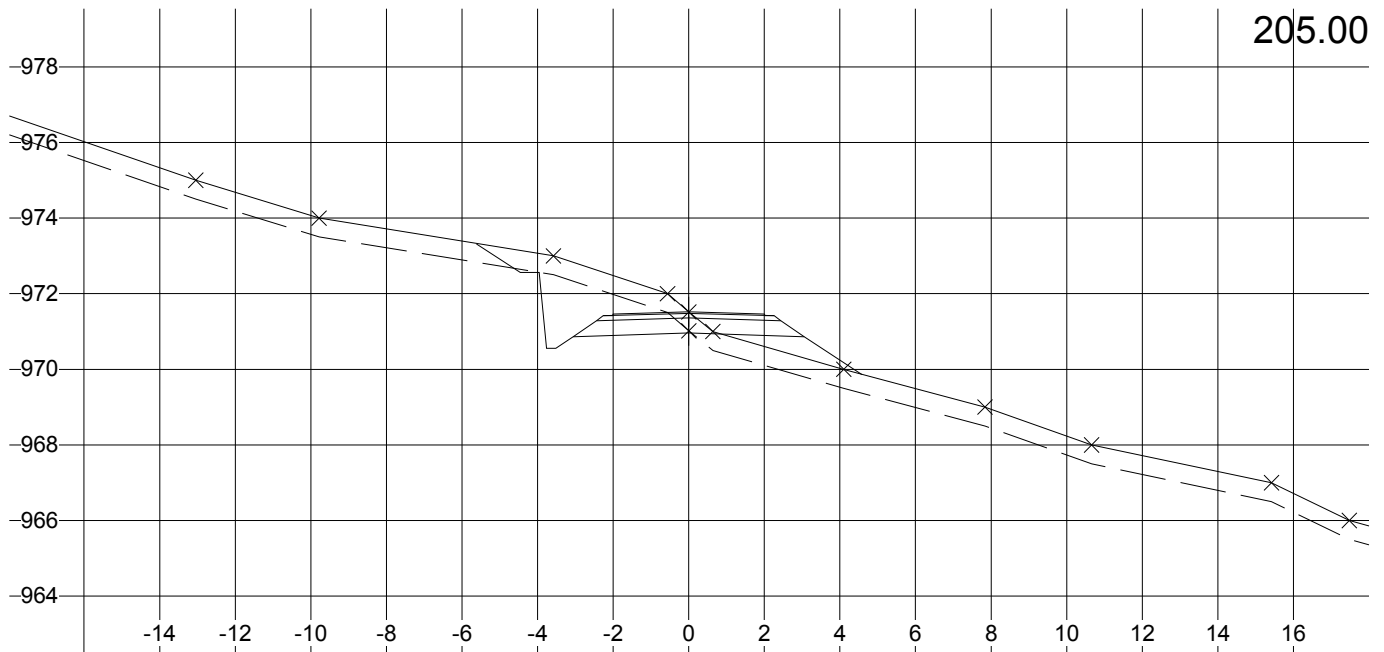

L:\IMA 4.7, Lisens: Plankontoret Hallvard Homme AS, Parsell: Parsell2.ps1

Rauland Invest AS Holtarvegen Veg2 Tverrprofil	Tegnet av AST	Saksbehandler
	Sidemannskontr.	Prosjektansvarlig AST
Plankontoret H. Homme AS 4747 Valle Tlf: 37 93 70 00, Fax: 37 93 74 74, E-Post: post@plankontoret.no	Dato 03.12.2009	Målestokk 1: 200
	Prosj.nr. 2219-V2	1: 200
	Tegn.nr. Tp-19	Rev.

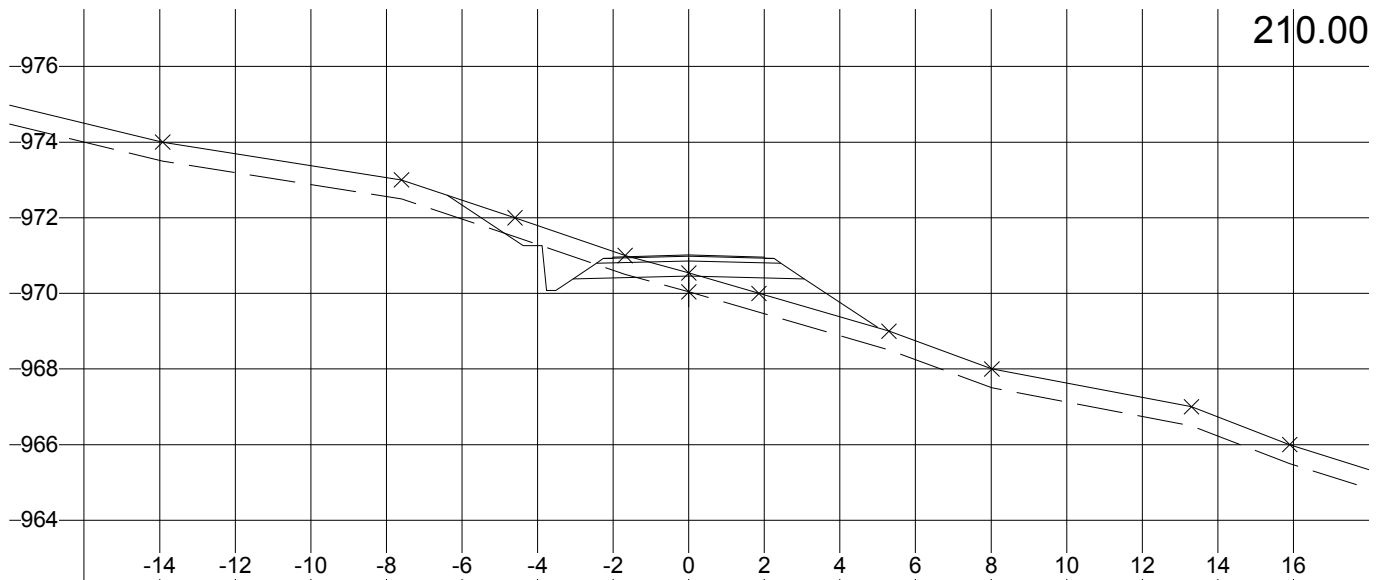
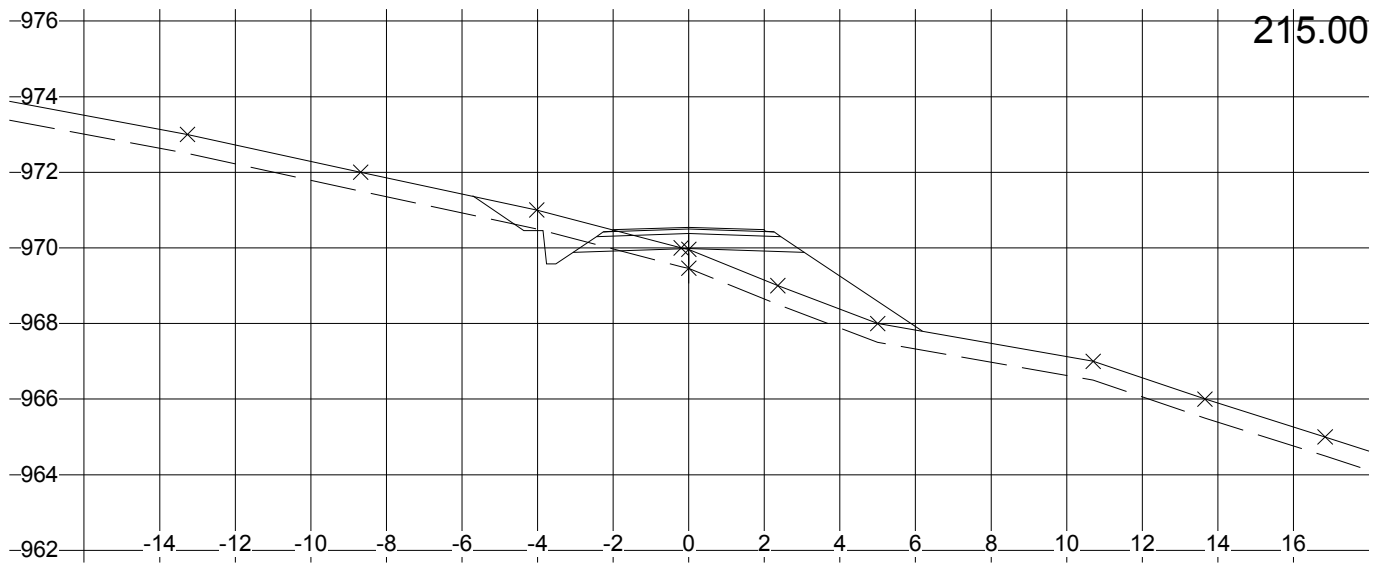

L:\IMA 4.7, Lisens: Plankontoret Hallvard Homme AS, Parsell: Parsell2.psl

Rauland Invest AS Holtarvegen Veg2 Tverrprofil	Tegnet av AST	Saksbehandler
	Sidemannskontr.	Prosjektansvarlig AST
Plankontoret H. Homme AS 4747 Valle Tlf: 37 93 70 00, Fax: 37 93 74 74, E-Post: post@plankontoret.no	Dato 03.12.2009	Målestokk 1: 200
	Prosj.nr. 2219-V2	1: 200
	Tegn.nr. Tp-20	Rev.

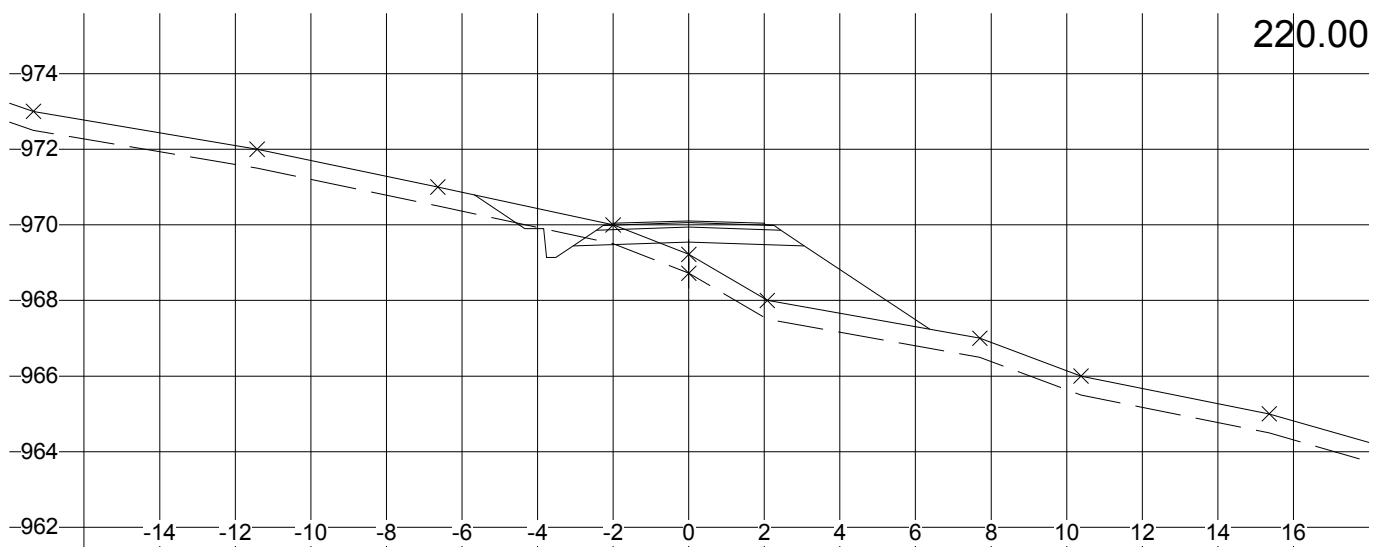
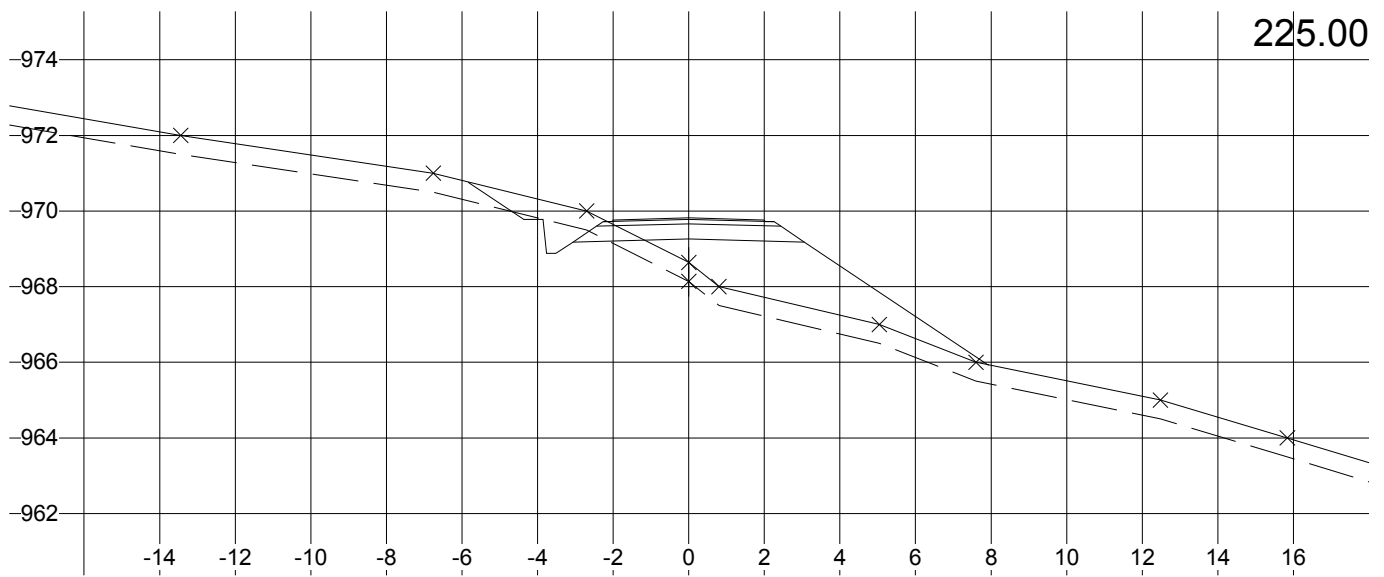

LIMA 4.7, Lisens: Plankontoret Hallvard Homme AS, Parsell: Parsell2.ps1

Rauland Invest AS Holtarvegen Veg2 Tverrprofil	Tegnet av AST	Saksbehandler
	Sidemannskont.	Prosjektansvarlig AST
Plankontoret H. Homme AS 4747 Valle Tlf: 37 93 70 00, Fax: 37 93 74 74, E-Post: post@plankontoret.no	Dato 03.12.2009	Målestokk 1: 200
	Prosj.nr. 2219-V2	1: 200
	Tegn.nr. Tp-21	Rev.

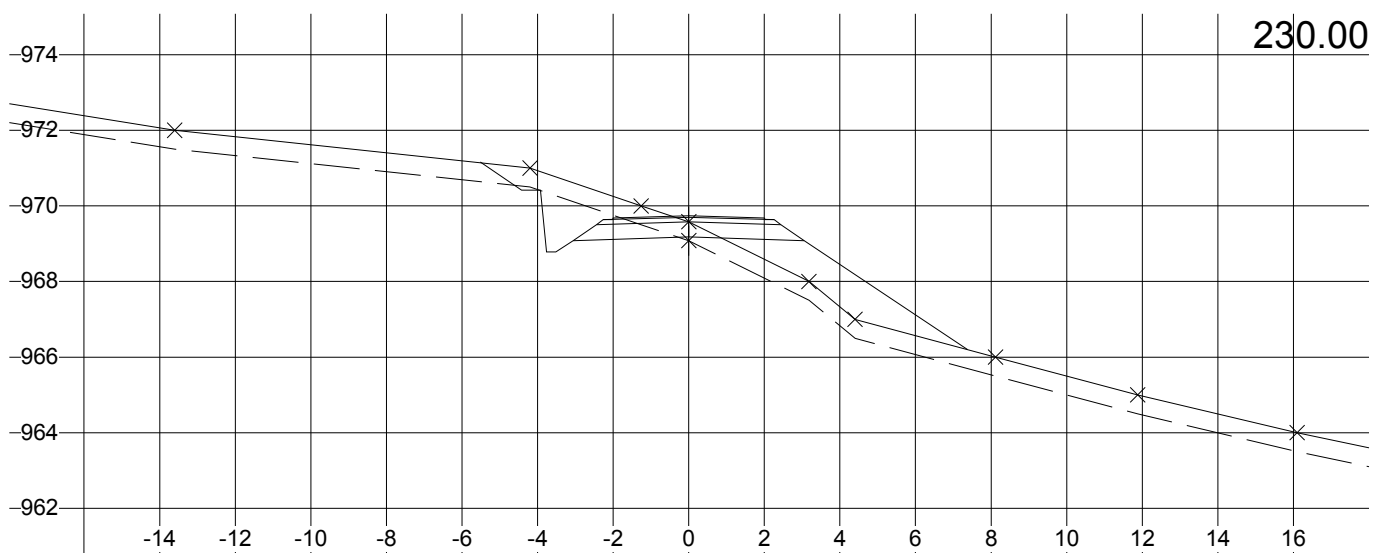
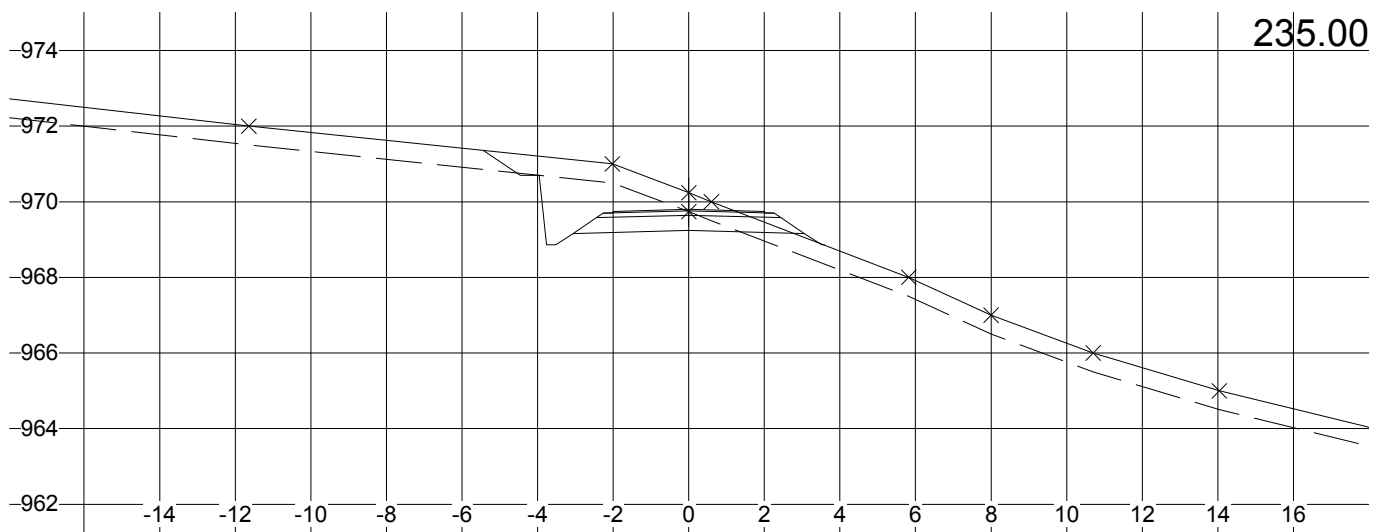

L:\IMA 4.7, Lisens: Plankontoret Hallvard Homme AS, Parsell: Parsell2.psl

Rauland Invest AS Holtarvegen Veg2 Tverrprofil	Tegnet av AST	Saksbehandler
	Sidemannsktr.	Prosjektansvarlig AST
Plankontoret H. Homme AS 4747 Valle Tlf: 37 93 70 00, Fax: 37 93 74 74, E-Post: post@plankontoret.no	Dato 03.12.2009	Målestokk 1: 200
	Prosj.nr. 2219-V2	1: 200
	Tegn.nr. Tp-22	Rev.

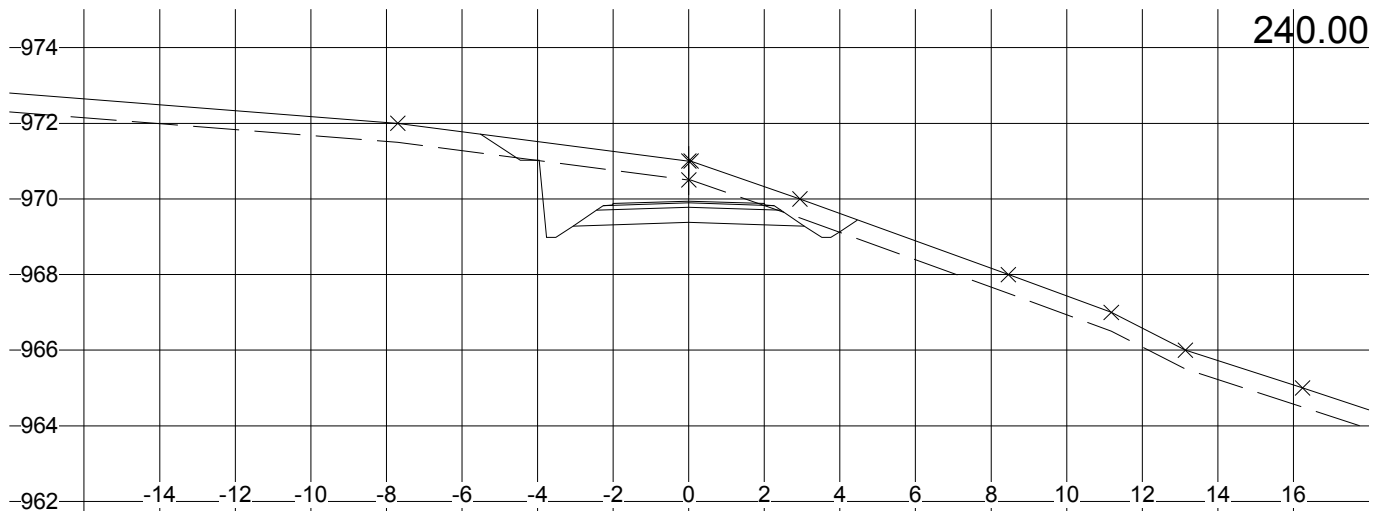
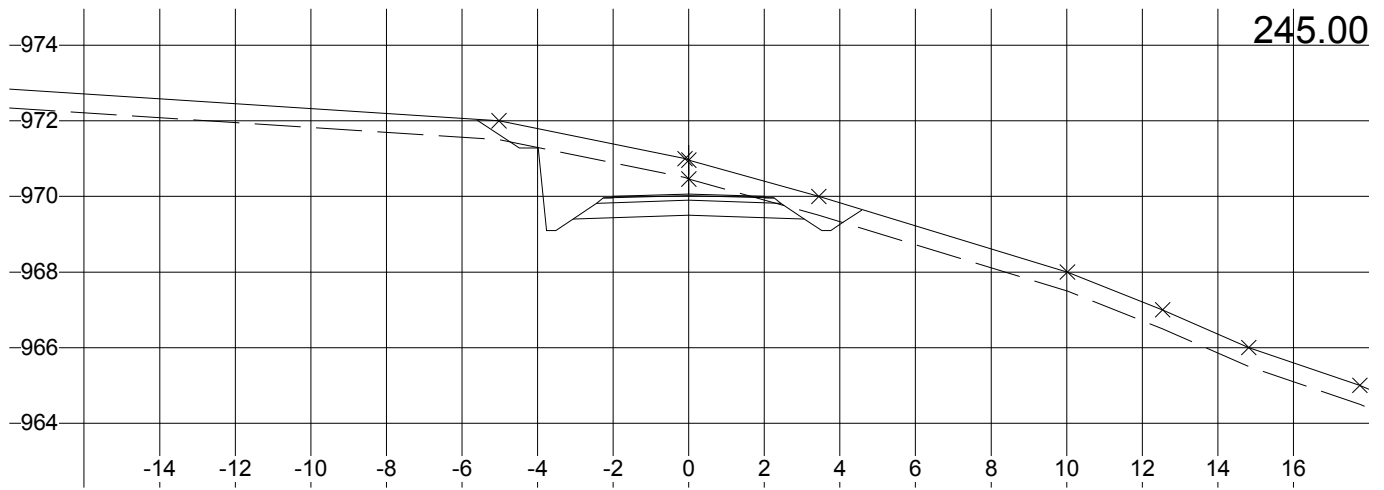
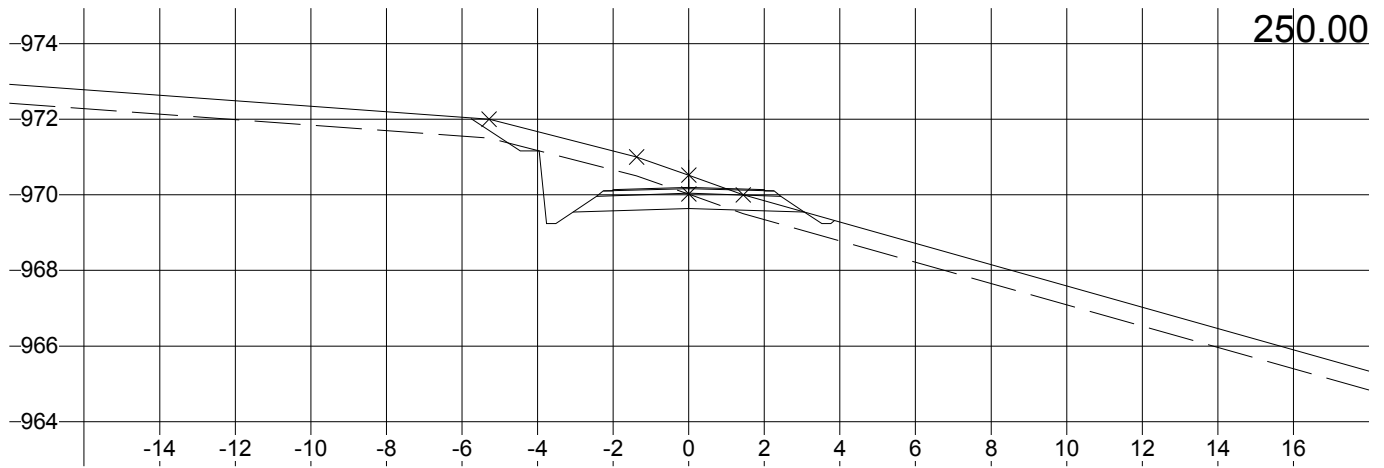

L:\IMA 4.7. Lisen: Plankontoret Hallvard Homme AS, Parsell: Parsell2.psl

Rauland Invest AS Holtarvegen Veg2 Tverrprofil	Tegnet av AST	Saksbehandler
	Sidemannskontnr.	Prosjektansvarlig AST
	Dato 03.12.2009	Målestokk 1: 200
	Prosj.nr. 2219-V2	1: 200
Plankontoret H. Homme AS 4747 Valle Tlf: 37 93 70 00, Fax: 37 93 74 74, E-Post: post@plankontoret.no	Tegn.nr. Tp-23	Rev.

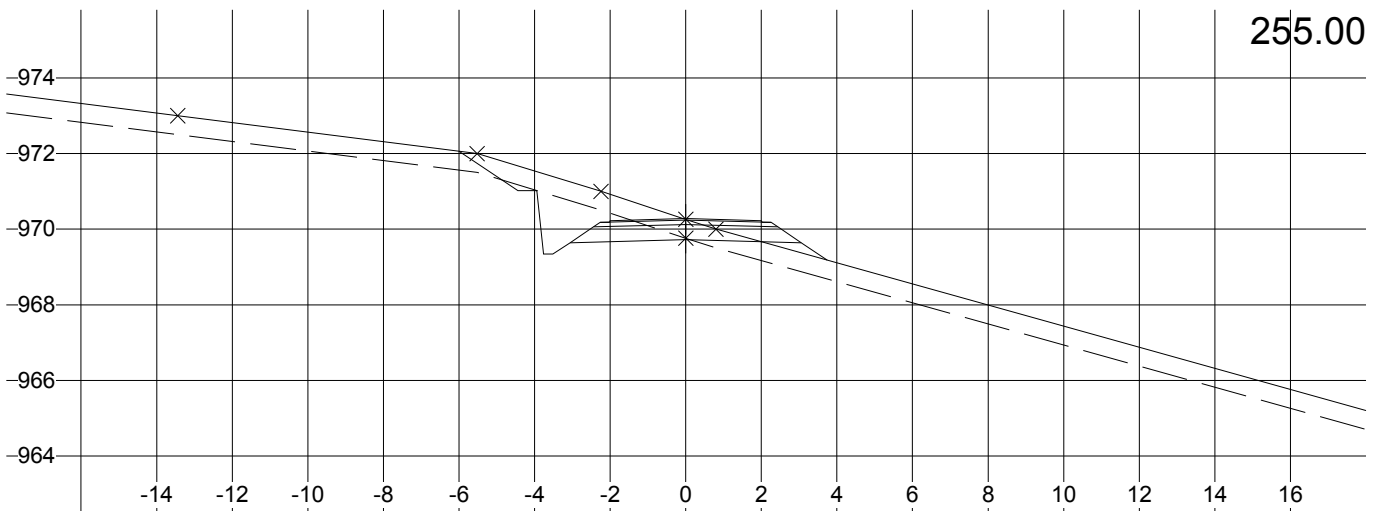
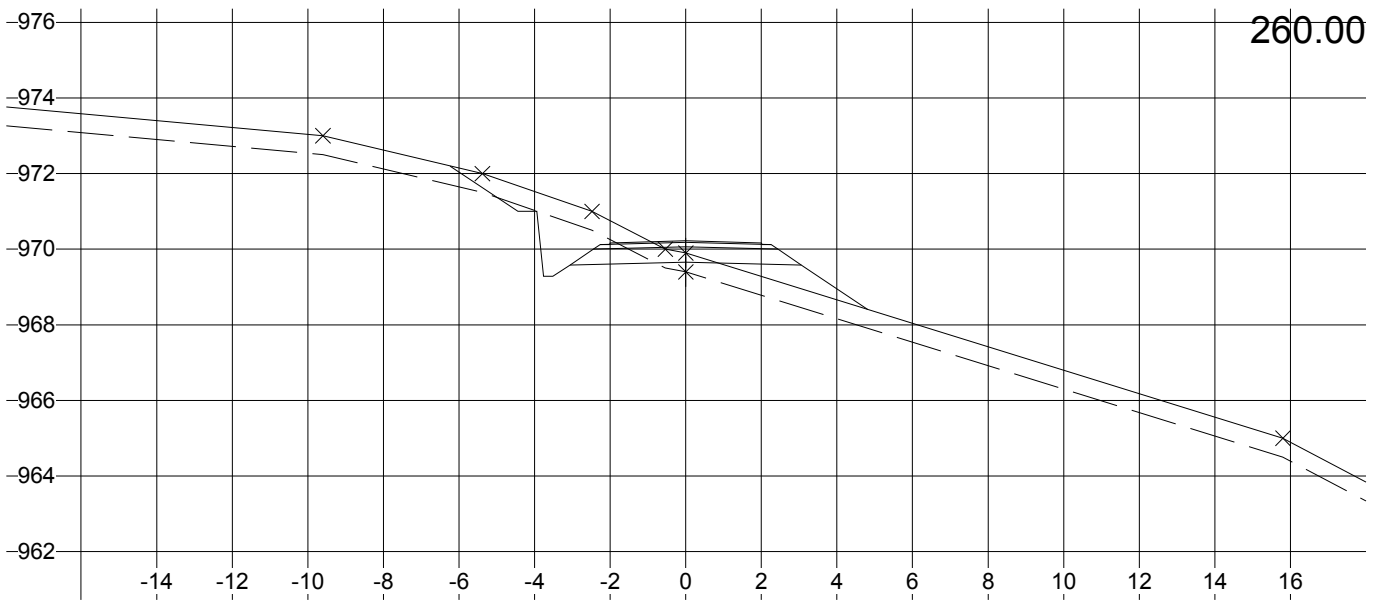

L:\IMA 4.7, Lisens: Plankontoret Hallvard Homme AS, Parsell: Parsell2.psl

Rauland Invest AS Holtarvegen Veg2 Tverrprofil	Tegnet av AST	Saksbehandler
	Sidemannskontr.	Prosjektansvarlig AST
Plankontoret H. Homme AS 4747 Valle Tlf: 37 93 70 00, Fax: 37 93 74 74, E-Post: post@plankontoret.no	Dato 03.12.2009	Målestokk 1: 200
	Prosj.nr. 2219-V2	1: 200
	Tegn.nr. Tp-24	Rev.

270.00

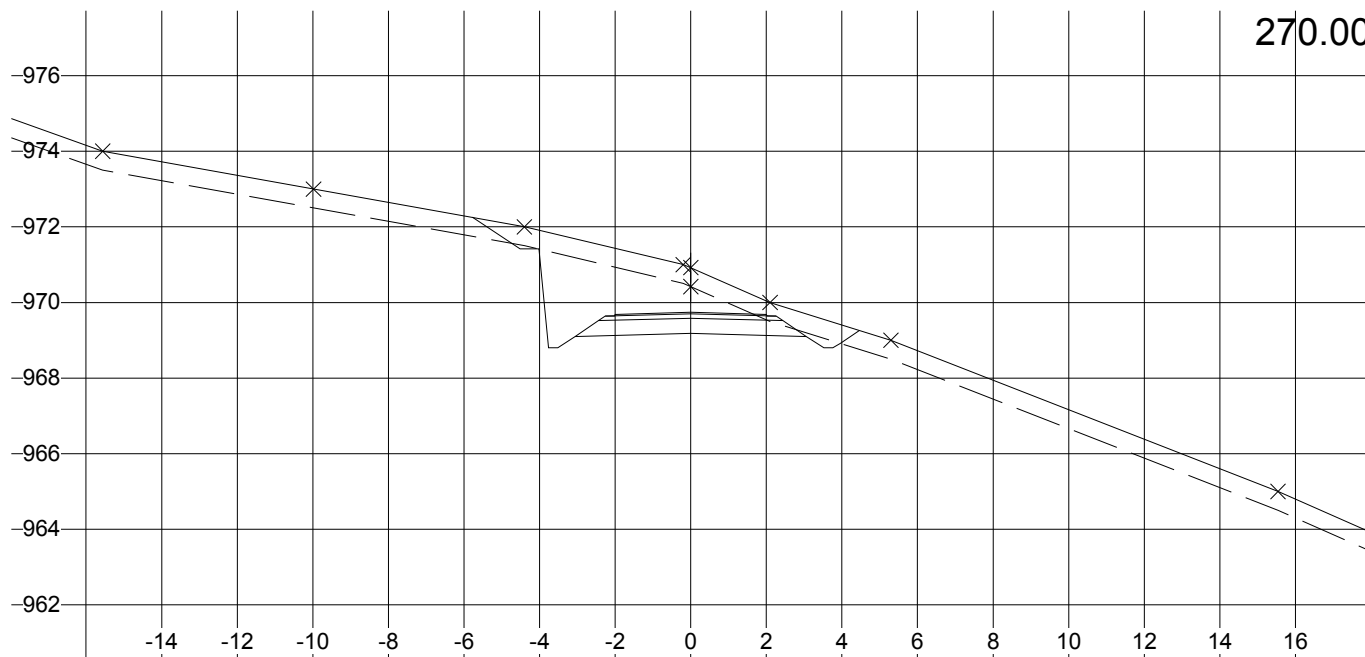

265.00

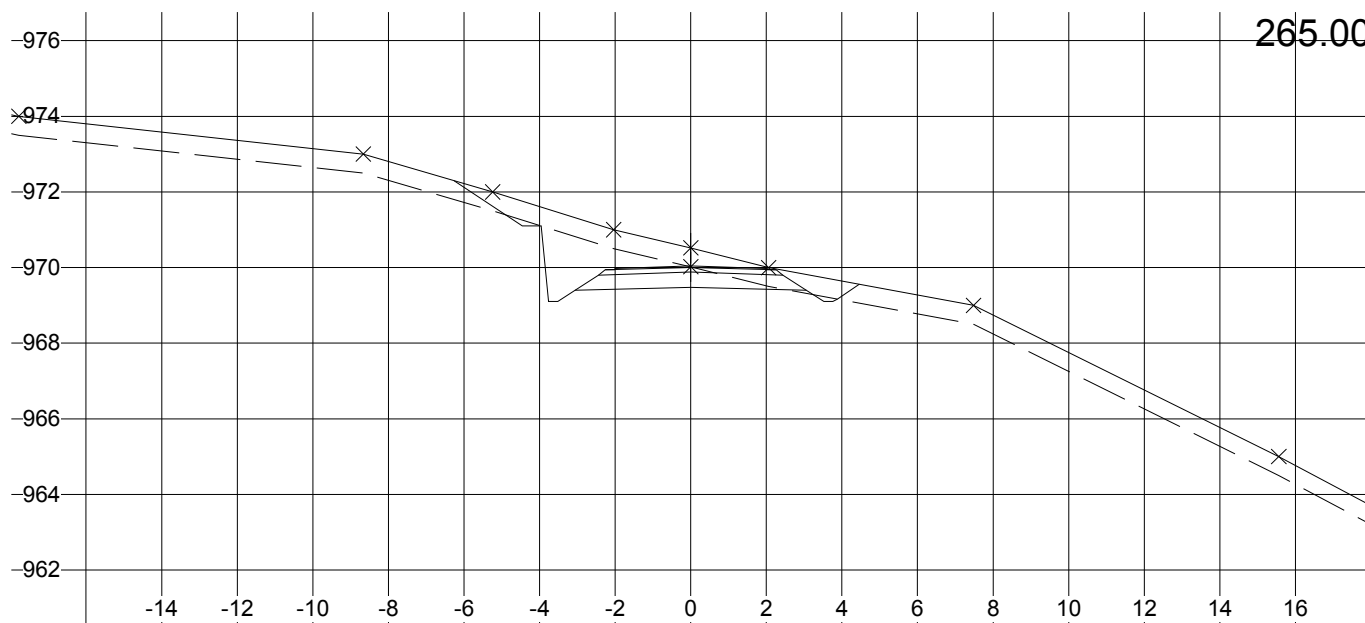

L:\IMA 4.7, Lisens: Plankontoret Hallvard Homme AS, Parsell: Parsell2.ps1

Rauland Invest AS Holtarvegen Veg2 Tverrprofil	Tegnet av AST	Saksbehandler
	Sidemannskontr.	Prosjektansvarlig AST
Plankontoret H. Homme AS 4747 Valle Tlf: 37 93 70 00, Fax: 37 93 74 74, E-Post: post@plankontoret.no	Dato 03.12.2009	Målestokk 1: 200
	Prosj.nr. 2219-V2	1: 200
	Tegn.nr. Tp-25	Rev.

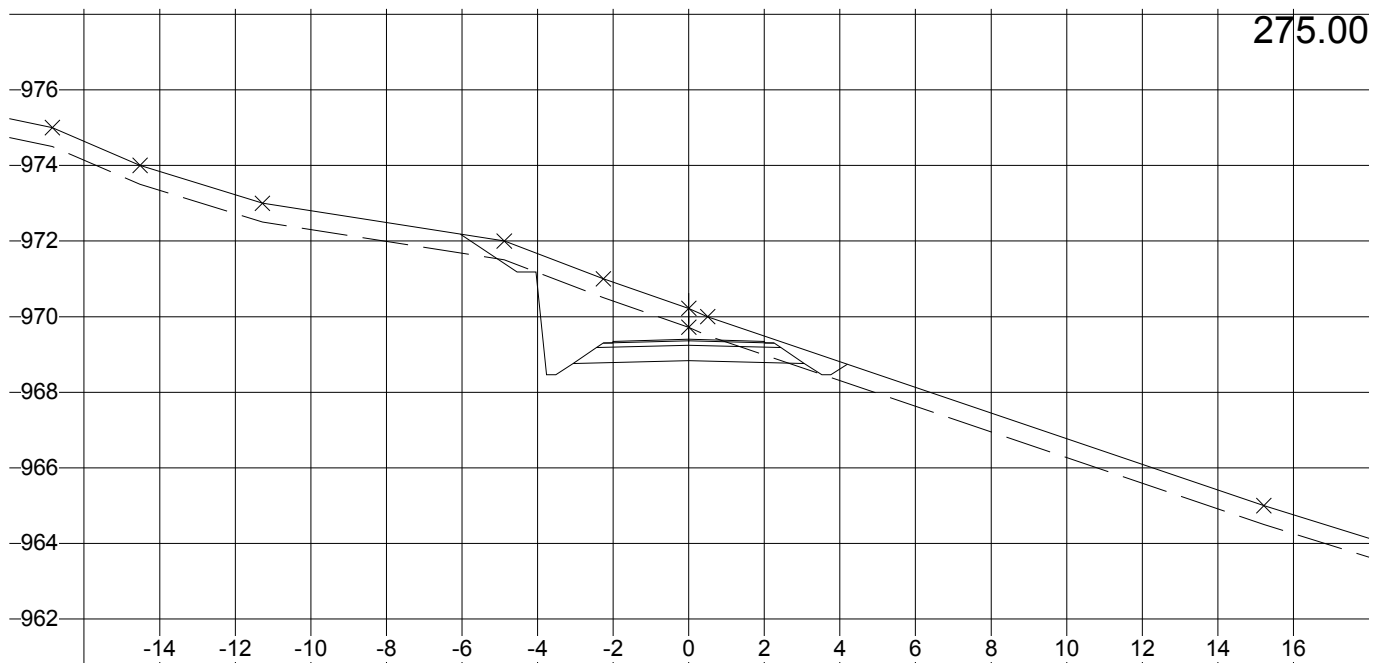
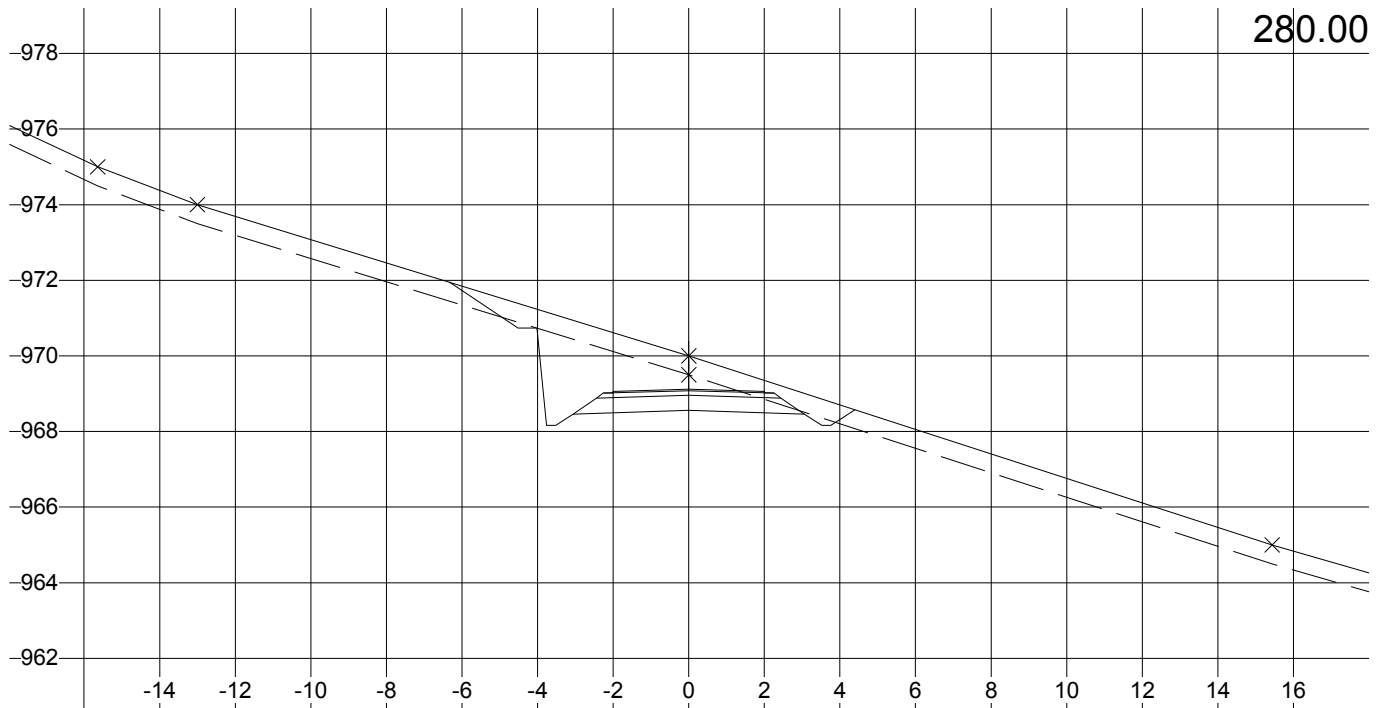

L:\IMA 4.7, Lisens: Plankontoret Hallvard Homme AS, Parsell: Parsell2.psl

Rauland Invest AS Holtarvegen Veg2 Tverrprofil	Tegnet av AST	Saksbehandler
	Sidemannskontr.	Prosjektansvarlig AST
Plankontoret H. Homme AS 4747 Valle Tlf: 37 93 70 00, Fax: 37 93 74 74, E-Post: post@plankontoret.no	Dato 03.12.2009	Målestokk 1: 200
	Prosj.nr. 2219-V2	1: 200
	Tegn.nr. Tp-26	Rev.

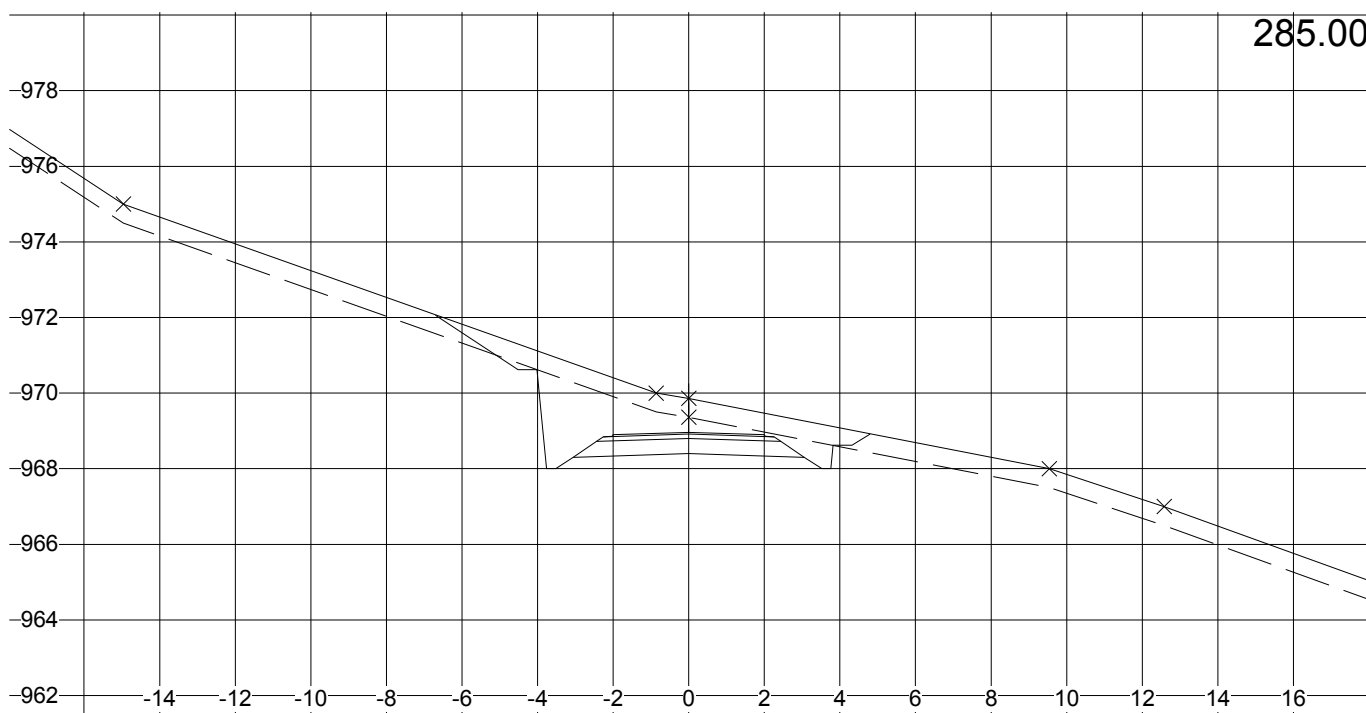
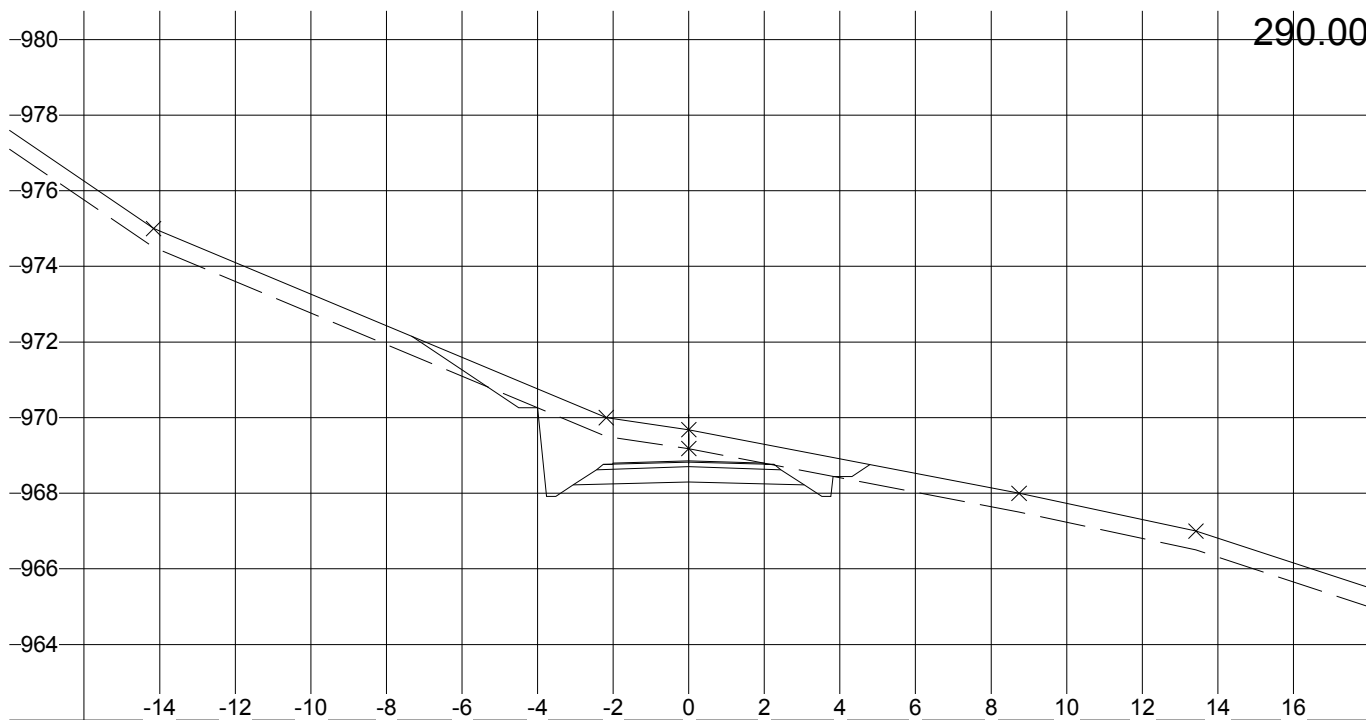

L:\IMA 4.7, Lisens: Plankontoret Hallvard Homme AS, Parsell: Parsell2.psl

Rauland Invest AS Holtarvegen Veg2 Tverrprofil	Tegnet av AST	Saksbehandler
	Sidemannskontr.	Prosjektansvarlig AST
	Dato 03.12.2009	Målestokk 1: 200
	Prosj.nr. 2219-V2	1: 200
Plankontoret H. Homme AS 4747 Valle Tlf: 37 93 70 00, Fax: 37 93 74 74, E-Post: post@plankontoret.no	Tegn.nr. Tp-27	Rev.

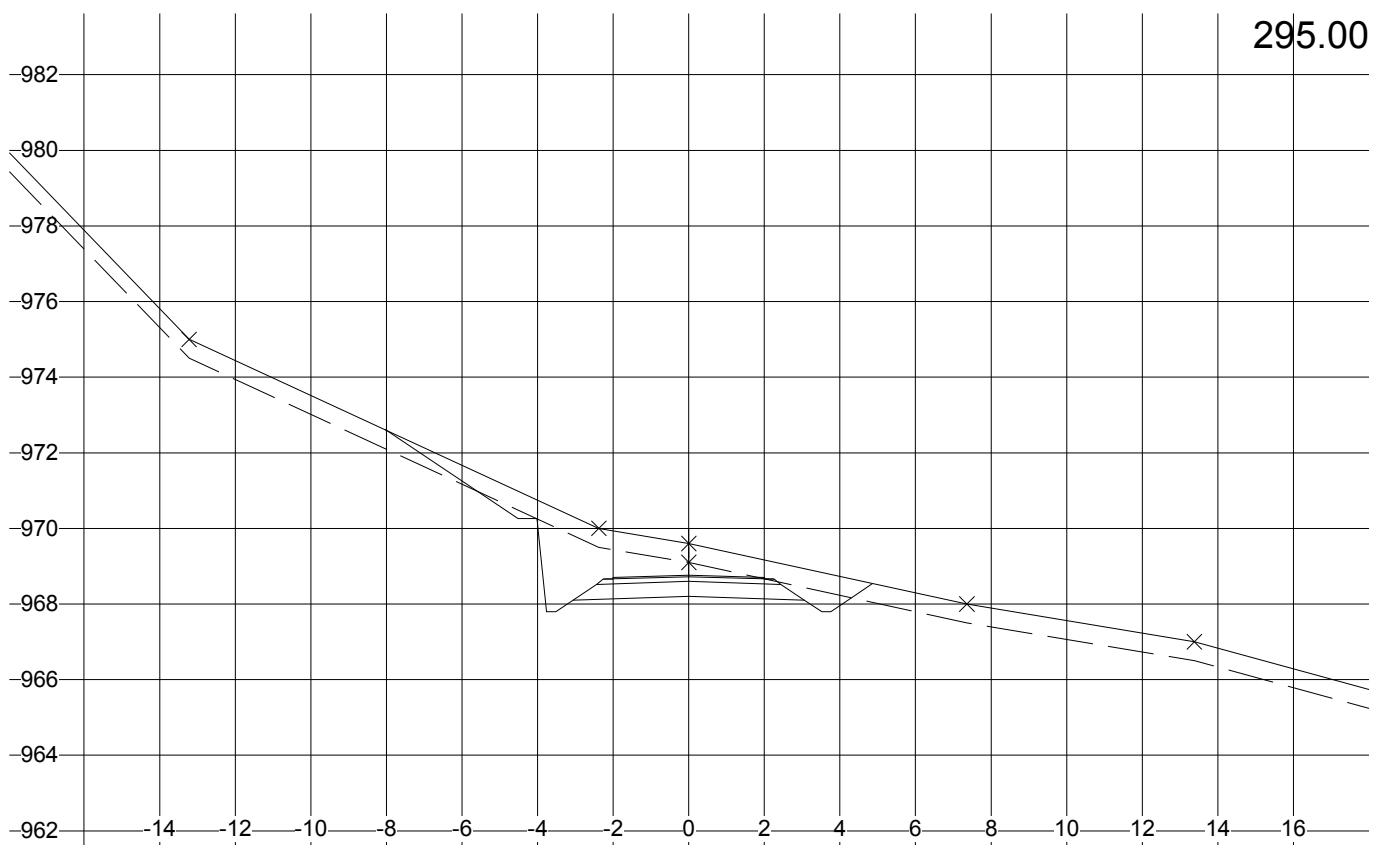

Rauland Invest AS Holtarvegen Veg2 Tverrprofil	Tegnet av AST	Saksbehandler
	Sidemannskontr.	Prosjektansvarlig AST
Plankontoret H. Homme AS 4747 Valle Tlf: 37 93 70 00, Fax: 37 93 74 74, E-Post: post@plankontoret.no	Dato 03.12.2009	Målestokk 1: 200
	Prosj.nr. 2219-V2	1: 200
	Tegn.nr. Tp-28	Rev.

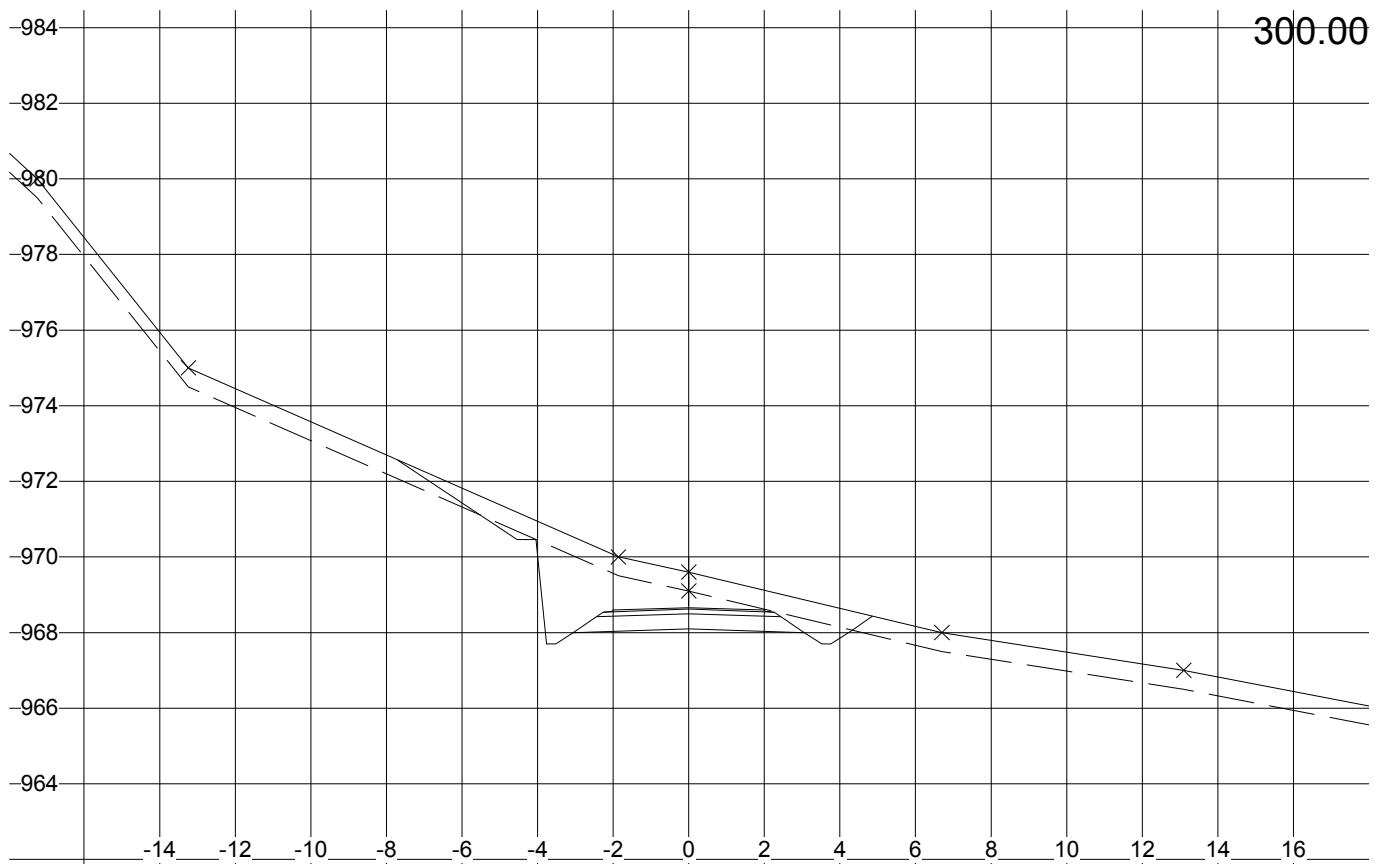

Rauland Invest AS Holtarvegen Veg2 Tverrprofil	Tegnet av AST	Saksbehandler
	Sidemannskontr.	Prosjektansvarlig AST
Plankontoret H. Homme AS 4747 Valle Tlf: 37 93 70 00, Fax: 37 93 74 74, E-Post: post@plankontoret.no	Dato 03.12.2009	Målestokk 1: 200
	Prosj.nr. 2219-V2	1: 200
	Tegn.nr. Tp-29	Rev.

310.00

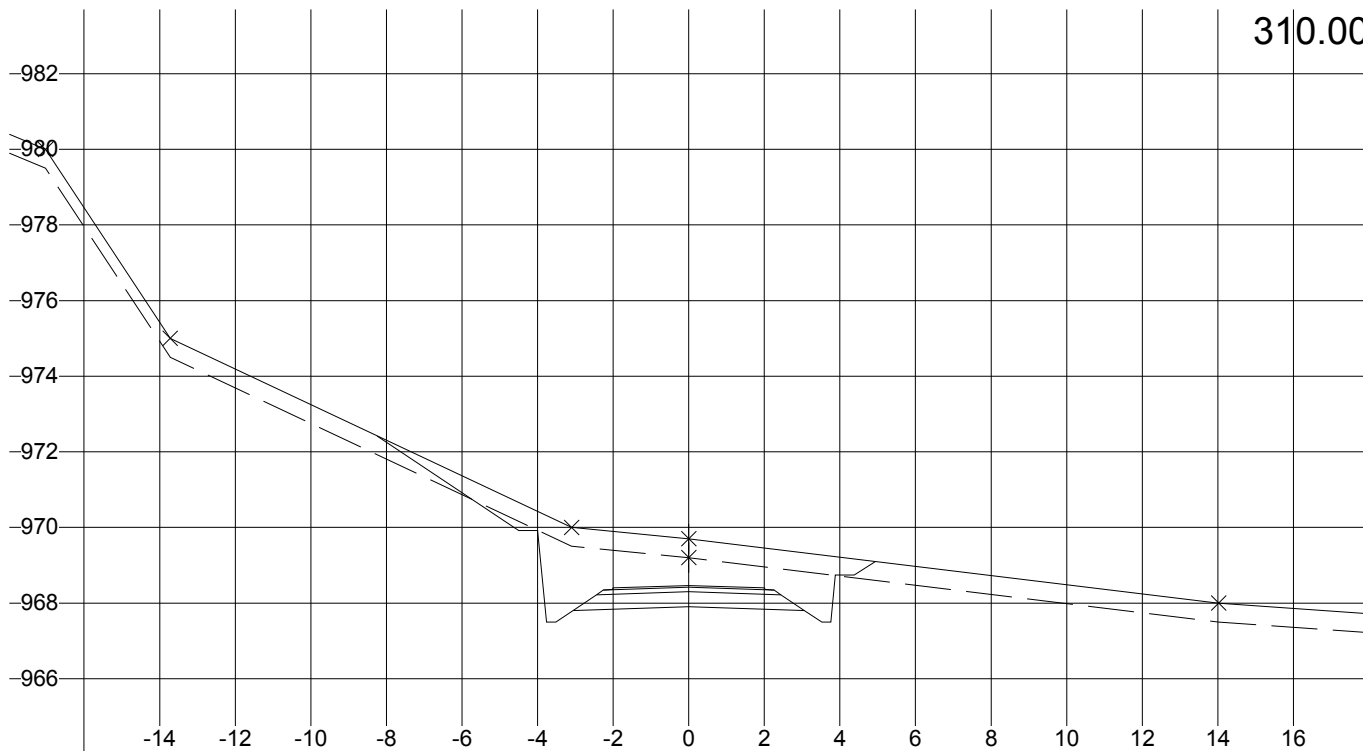

305.00

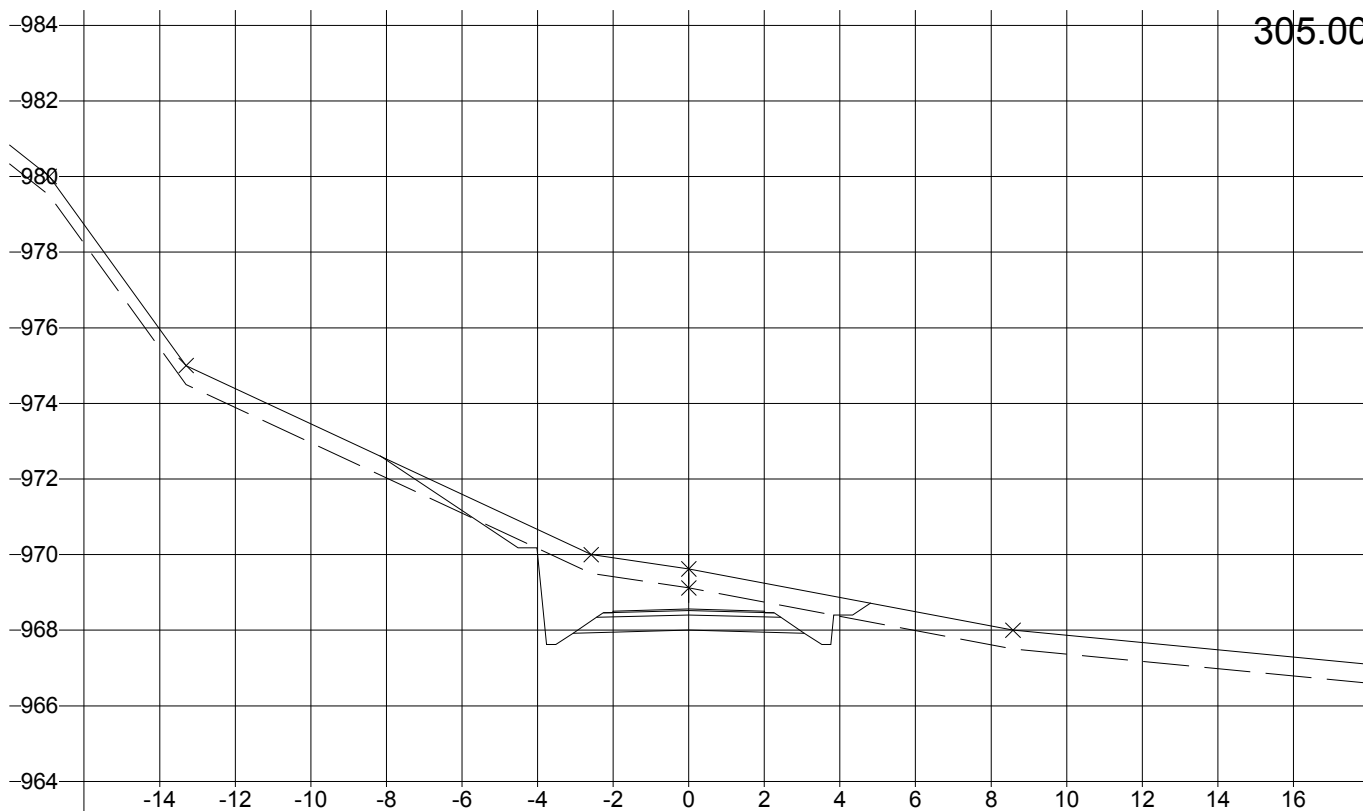

L:\IMA 4.7, Lisens: Plankontoret Hallvard Homme AS, Parsell: Parsell2.psl

Rauland Invest AS Holtarvegen Veg2 Tverrprofil	Tegnet av AST	Saksbehandler
	Sidemannskontr.	Prosjektansvarlig AST
	Dato 03.12.2009	Målestokk 1: 200 1: 200
	Prosj.nr. 2219-V2	Rev.
Plankontoret H. Homme AS 4747 Valle Tlf: 37 93 70 00, Fax: 37 93 74 74, E-Post: post@plankontoret.no	Tegn.nr. Tp-30	

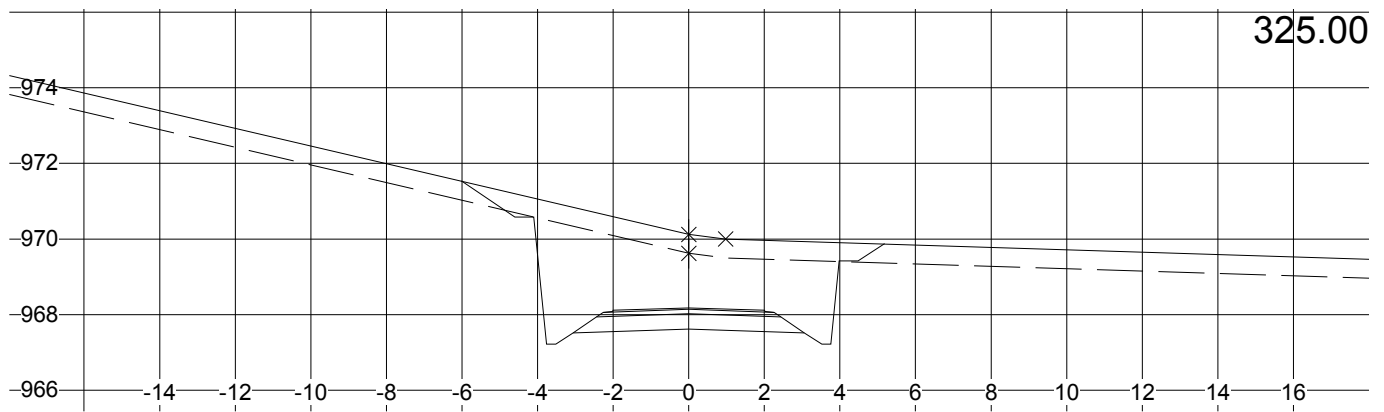

325.00

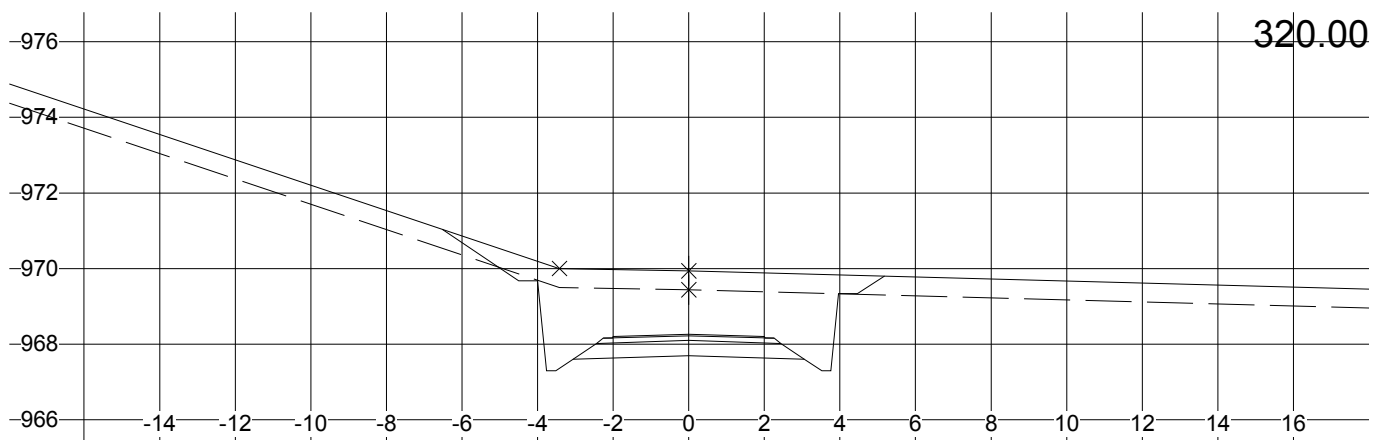

320.00

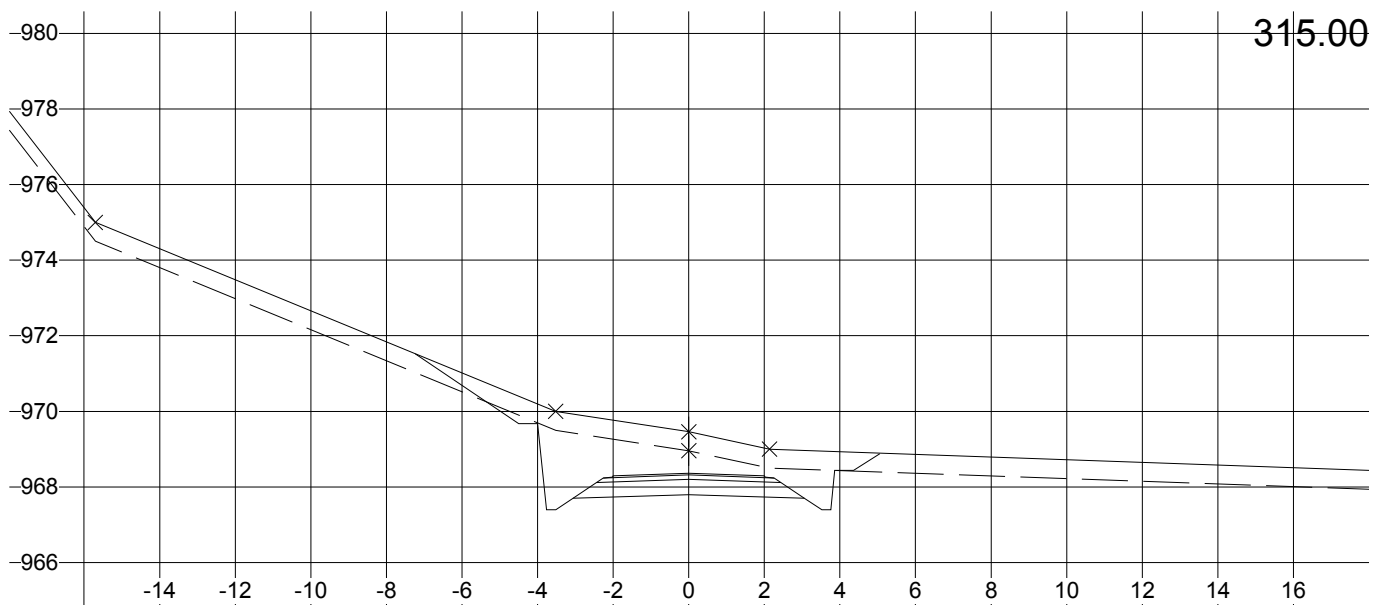

315.00

Rauland Invest AS Holtarvegen Veg2 Tverrprofil	Tegnet av AST	Saksbehandler
	Sidemannsktr.	Prosjektansvarlig AST
	Dato 03.12.2009	Målestokk 1: 200
	Prosj.nr. 2219-V2	1: 200
Plankontoret H. Homme AS 4747 Valle Tlf: 37 93 70 00, Fax: 37 93 74 74, E-Post: post@plankontoret.no	Tegn.nr. Tp-31	Rev.

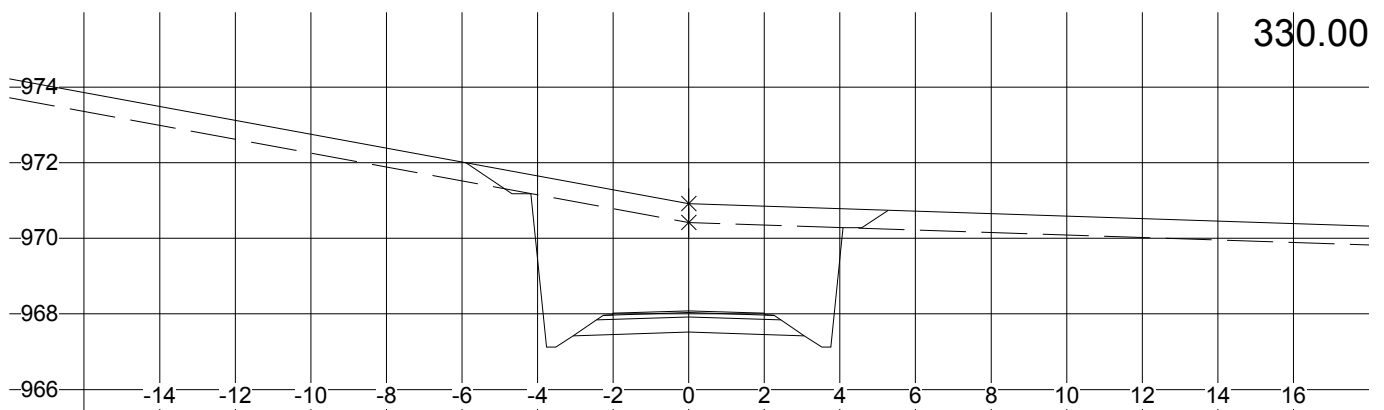
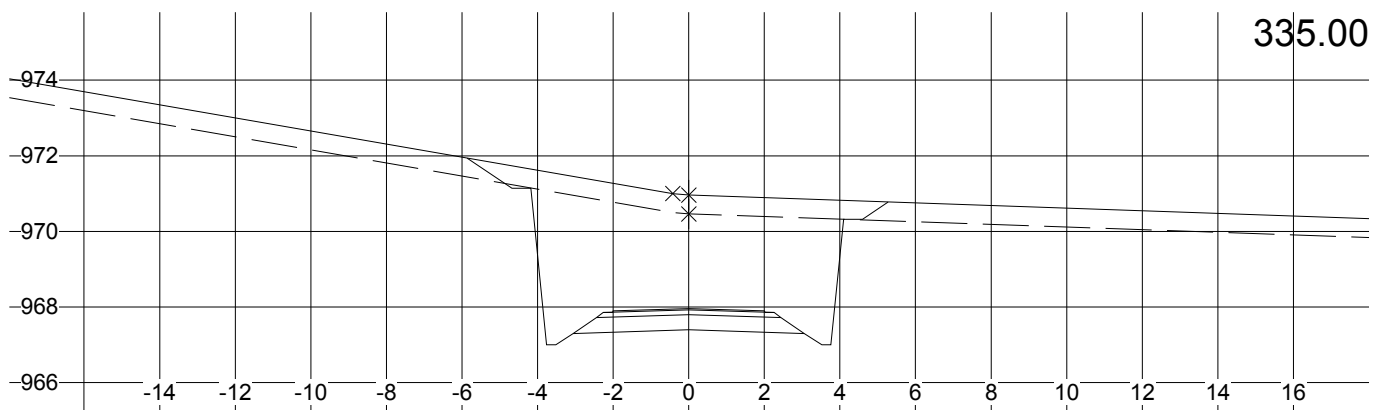
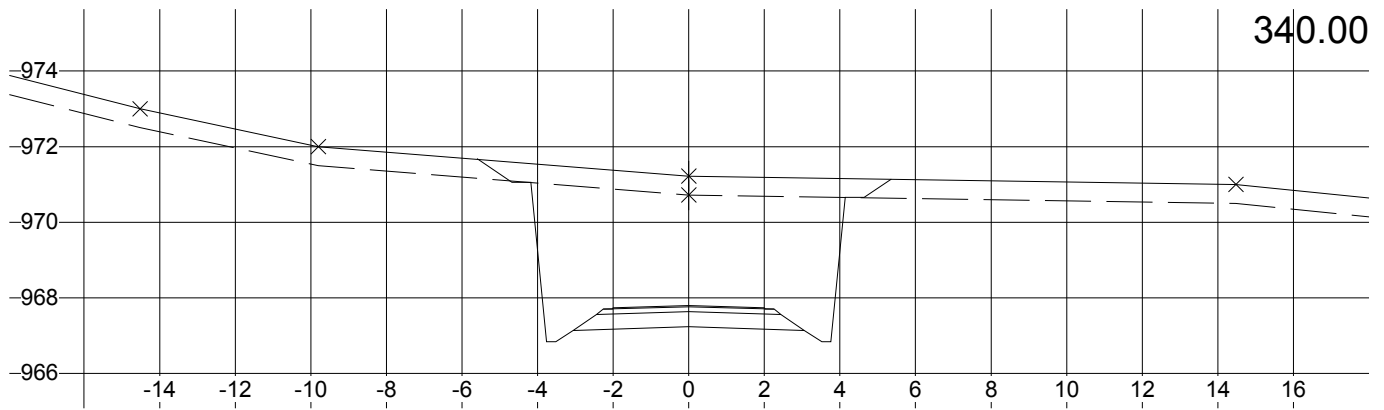

L:\IMA 4.7, Lisens: Plankontoret Hallvard Homme AS, Parsell: Parsell2.ps1

Rauland Invest AS Holtarvegen Veg2 Tverrprofil	Tegnet av AST	Saksbehandler
	Sidemannskontr.	Prosjektansvarlig AST
	Dato 03.12.2009	Målestokk 1: 200 1: 200
	Prosj.nr. 2219-V2	Rev.
Plankontoret H. Homme AS 4747 Valle Tlf: 37 93 70 00, Fax: 37 93 74 74, E-Post: post@plankontoret.no	Tegn.nr. Tp-32	

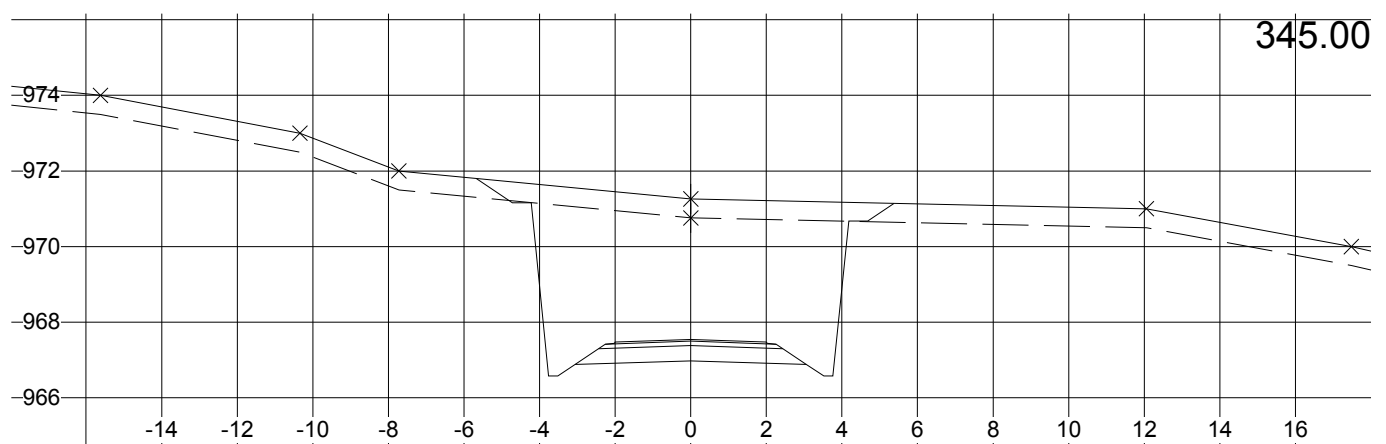
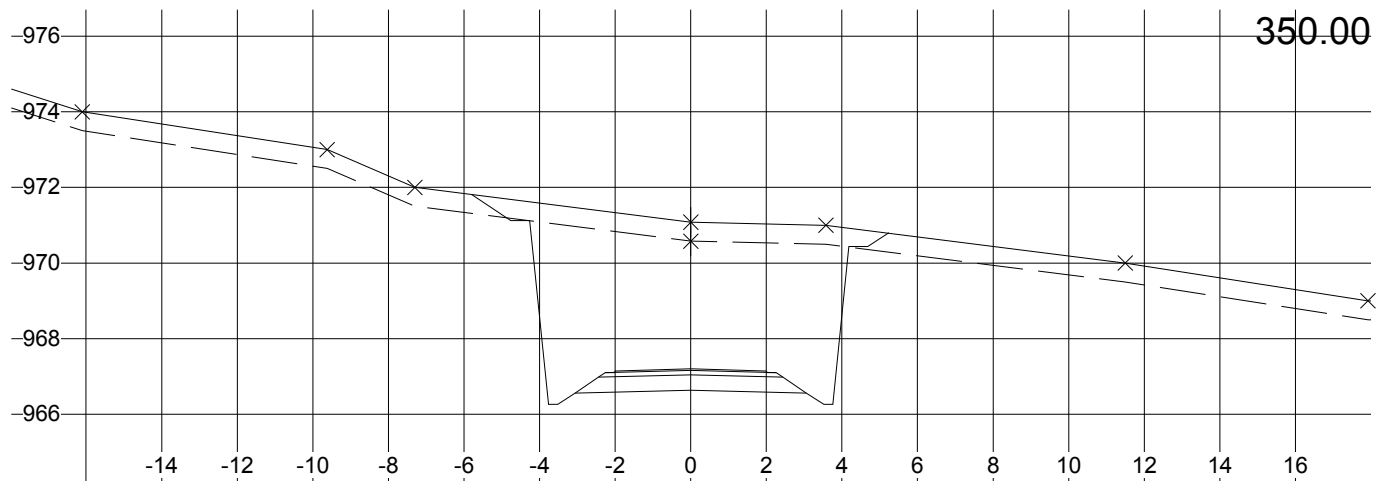
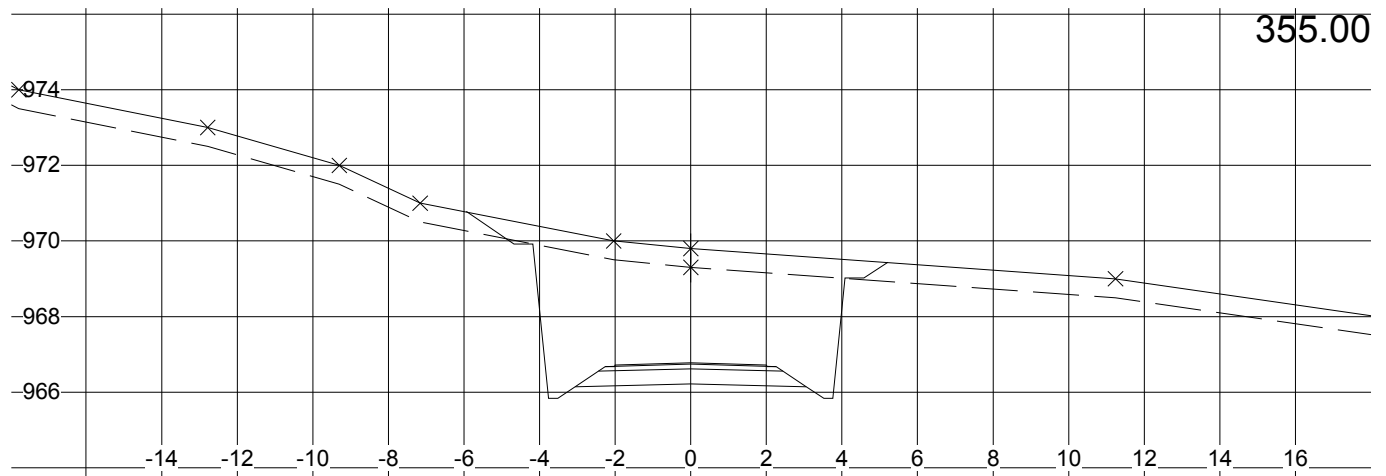

LIMA 4.7, Lisens: Plankontoret Hallvard Homme AS, Parsell: Parsell2.psl

Rauland Invest AS Holtarvegen Veg2 Tverrprofil	Tegnet av AST	Saksbehandler
	Sidemannskontroll.	Prosjektansvarlig AST
	Dato 03.12.2009	Målestokk 1: 200
	Prosj.nr. 2219-V2	1: 200
Plankontoret H. Homme AS 4747 Valle Tlf: 37 93 70 00, Fax: 37 93 74 74, E-Post: post@plankontoret.no	Tegn.nr. Tp-33	Rev.

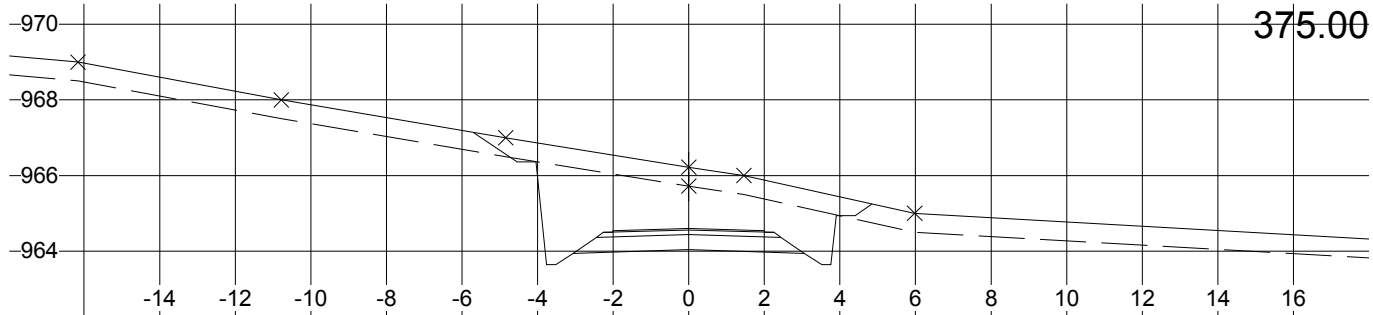

375.00

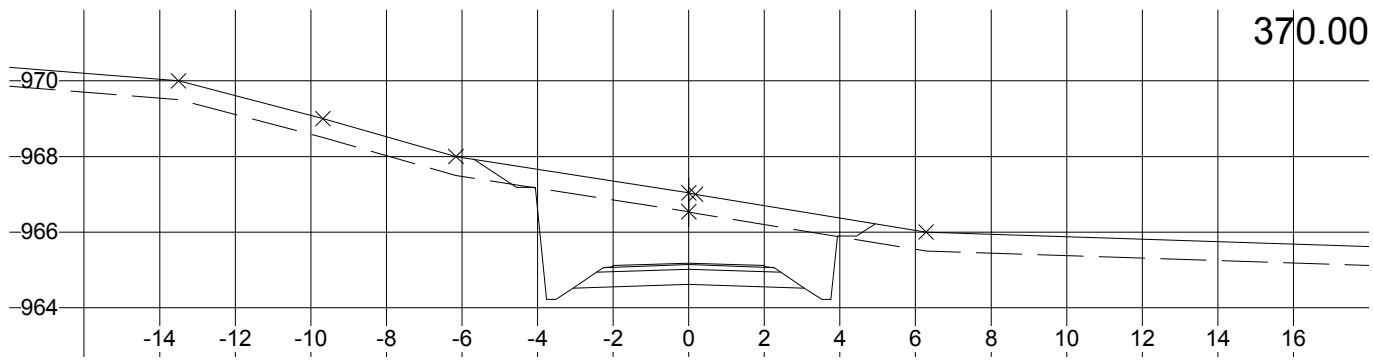

370.00

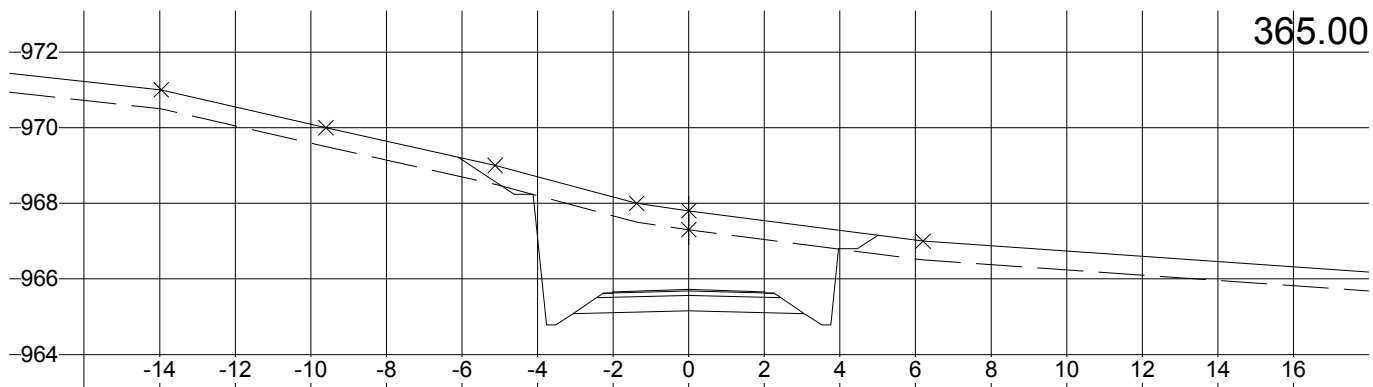

365.00

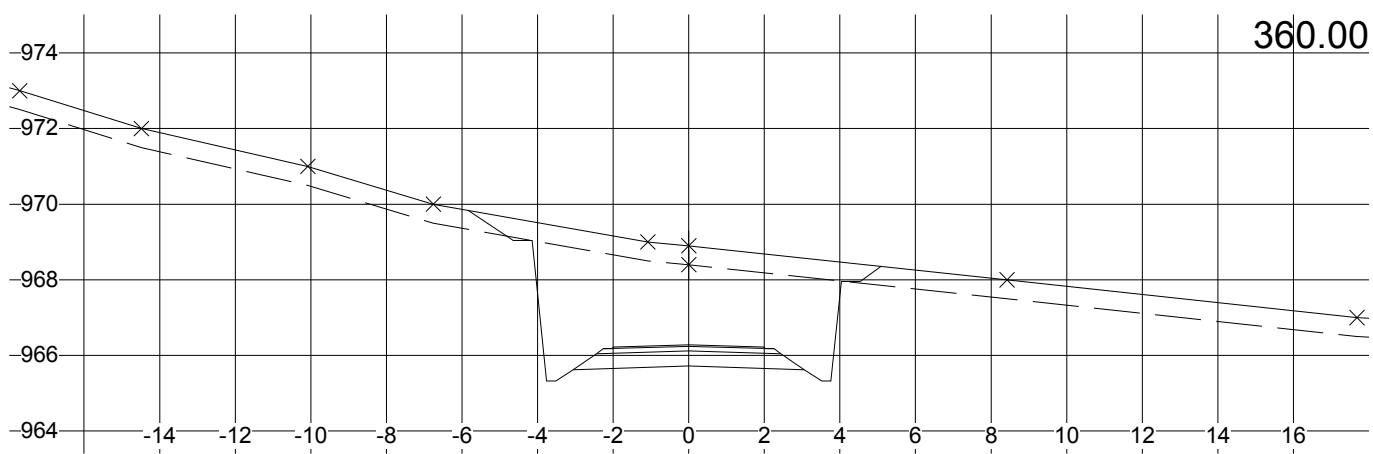

360.00

L:\IMA 4.7, Lisens: Plankontoret Hallvard Homme AS, Parsell: Parsell2.ps1

Rauland Invest AS Holtarvegen Veg2 Tverrprofil	Tegnet av AST	Saksbehandler
	Sidemannskonstr.	Prosjektansvarlig AST
	Dato 03.12.2009	Målestokk 1: 200 1: 200
	Prosj.nr. 2219-V2	Rev.
Plankontoret H. Homme AS 4747 Valle Tlf: 37 93 70 00, Fax: 37 93 74 74, E-Post: post@plankontoret.no	Tegn.nr. Tp-34	

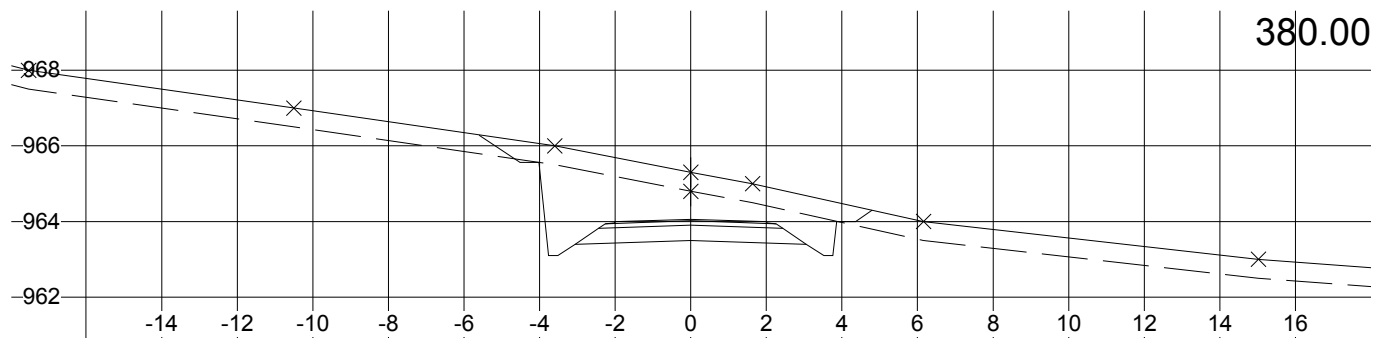
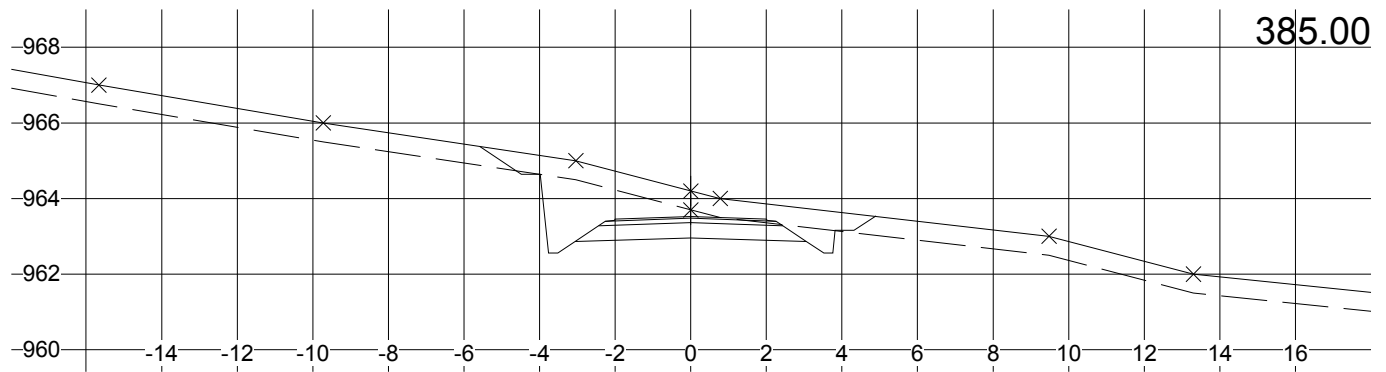
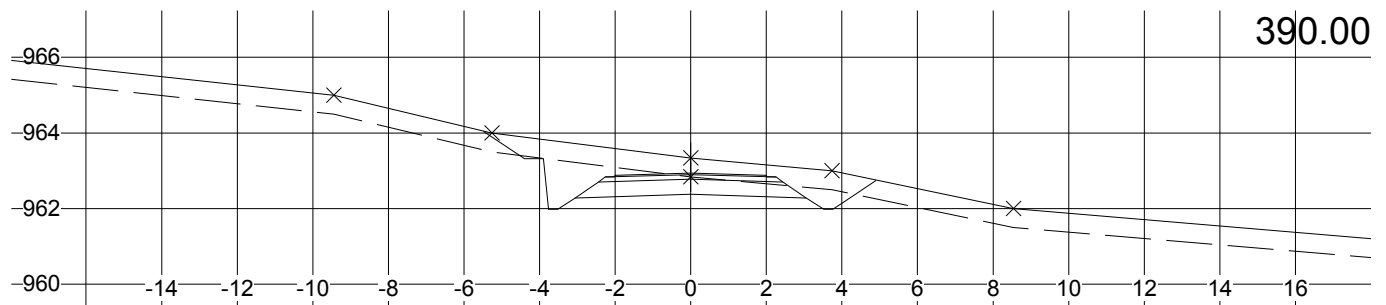
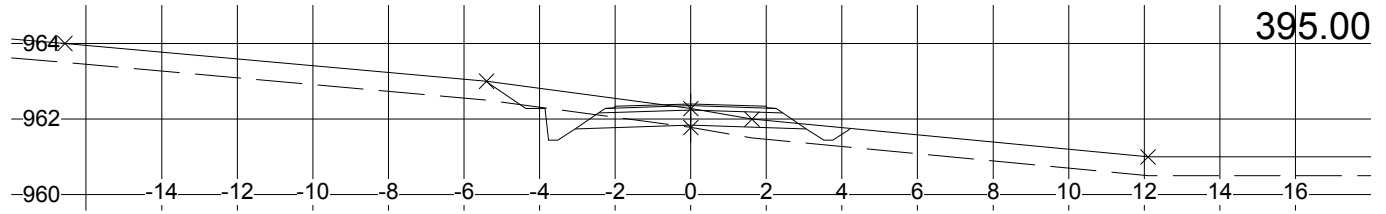
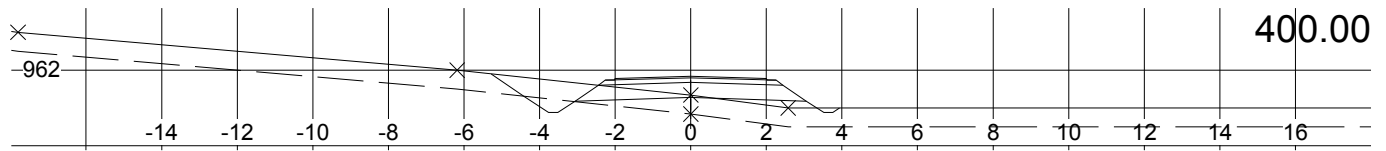

L:\IMA 4.7, Lisens: Plankontoret Hallvard Homme AS, Parsell: Parsell2.psl

Rauland Invest AS Holtarvegen Veg2 Tverrprofil	Tegnet av AST	Saksbehandler
	Sidemannkontr.	Prosjektansvarlig AST
Plankontoret H. Homme AS 4747 Valle Tlf: 37 93 70 00, Fax: 37 93 74 74, E-Post: post@plankontoret.no	Dato 03.12.2009	Målestokk 1: 200
	Prosj.nr. 2219-V2	1: 200
	Tegn.nr. Tp-35	Rev.

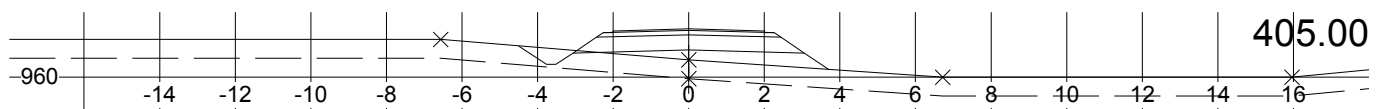
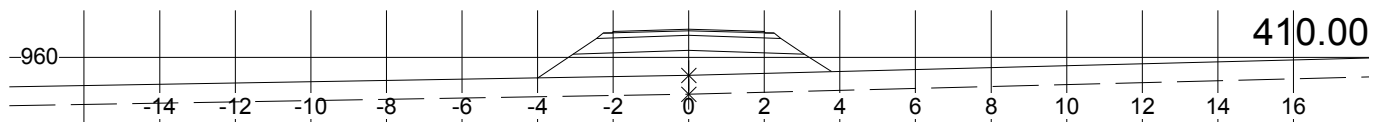
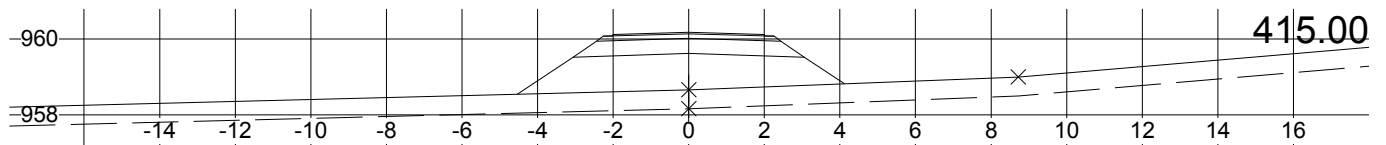
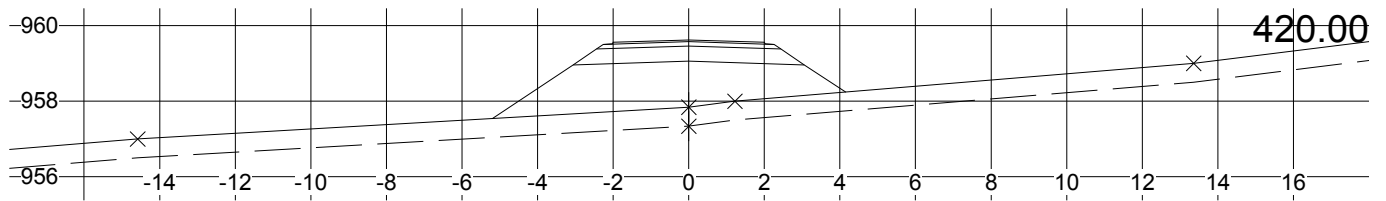
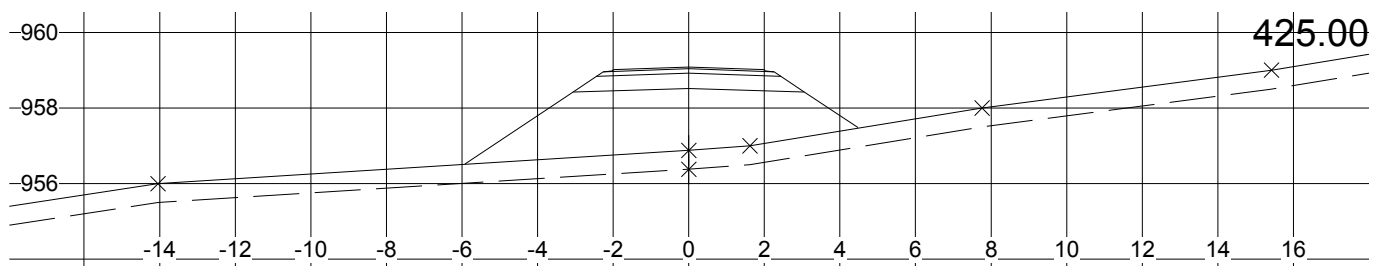
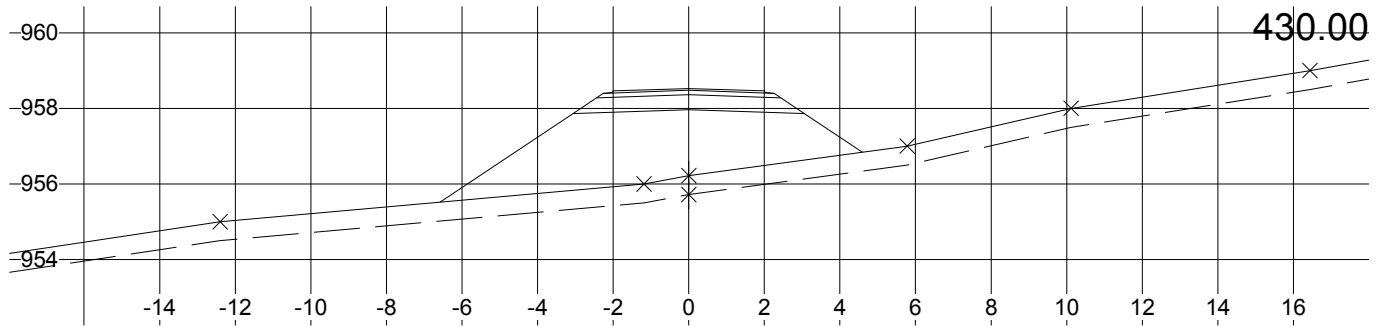

L:\IMA 4.7, Lisens: Plankontoret Hallvard Homme AS, Parsell: Parsell2.psl

Rauland Invest AS Holtarvegen Veg2 Tverrprofil	Tegnet av AST	Saksbehandler
	Sidemannskontnr.	Prosjektansvarlig AST
Plankontoret H. Homme AS 4747 Valle Tlf: 37 93 70 00, Fax: 37 93 74 74, E-Post: post@plankontoret.no	Dato 03.12.2009	Målestokk 1: 200 1: 200
	Prosj.nr. 2219-V2	
	Tegn.nr. Tp-36	Rev.

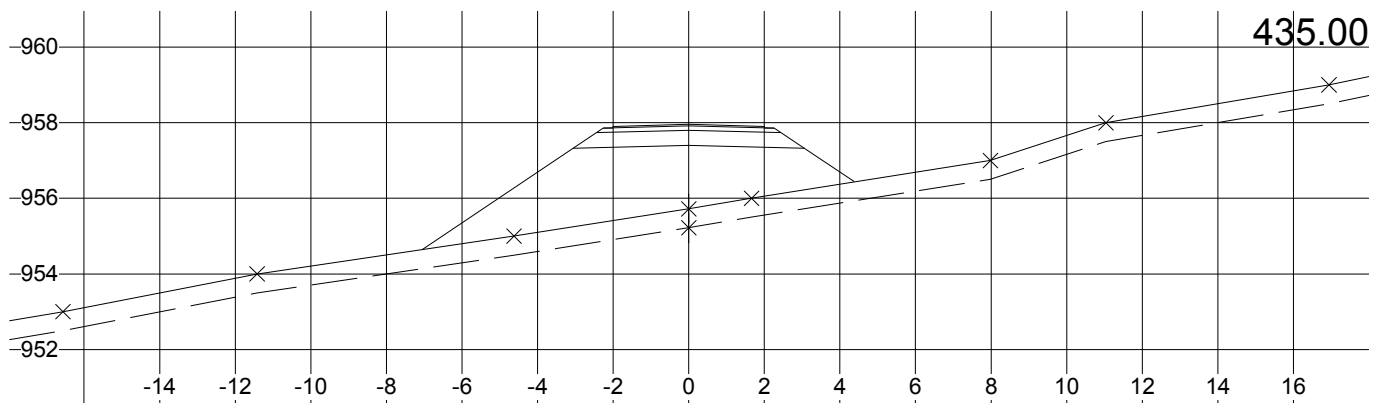
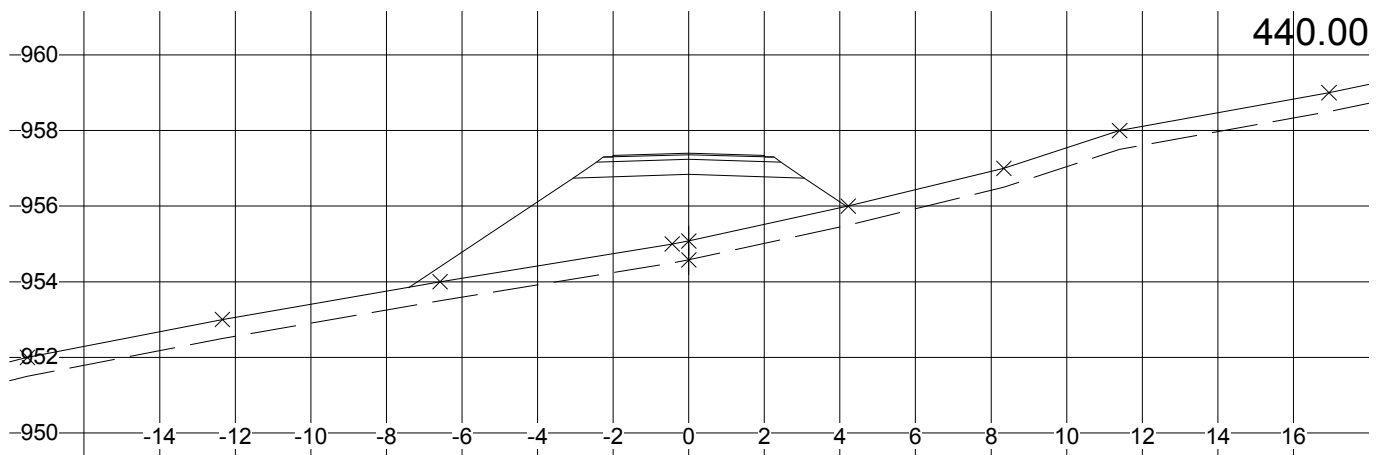
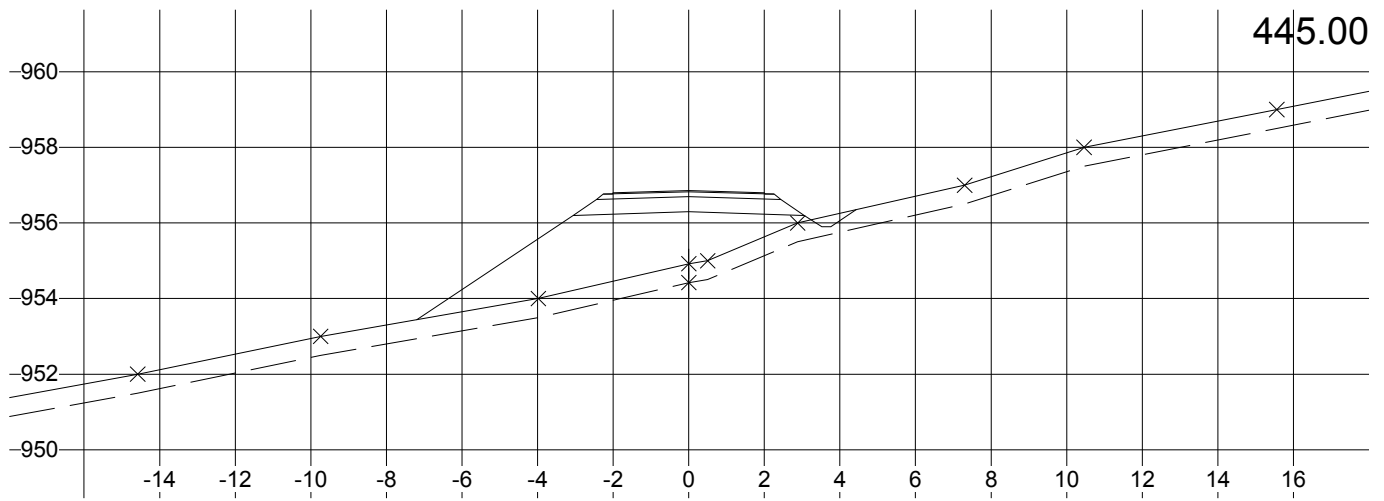

Rauland Invest AS Holtarvegen Veg2 Tverrprofil	Tegnet av AST	Saksbehandler
	Sidemannskontr.	Prosjektansvarlig AST
Plankontoret H. Homme AS 4747 Valle Tlf: 37 93 70 00, Fax: 37 93 74 74, E-Post: post@plankontoret.no	Dato 03.12.2009	Målestokk 1: 200
	Prosj.nr. 2219-V2	1: 200
	Tegn.nr. Tp-37	Rev.

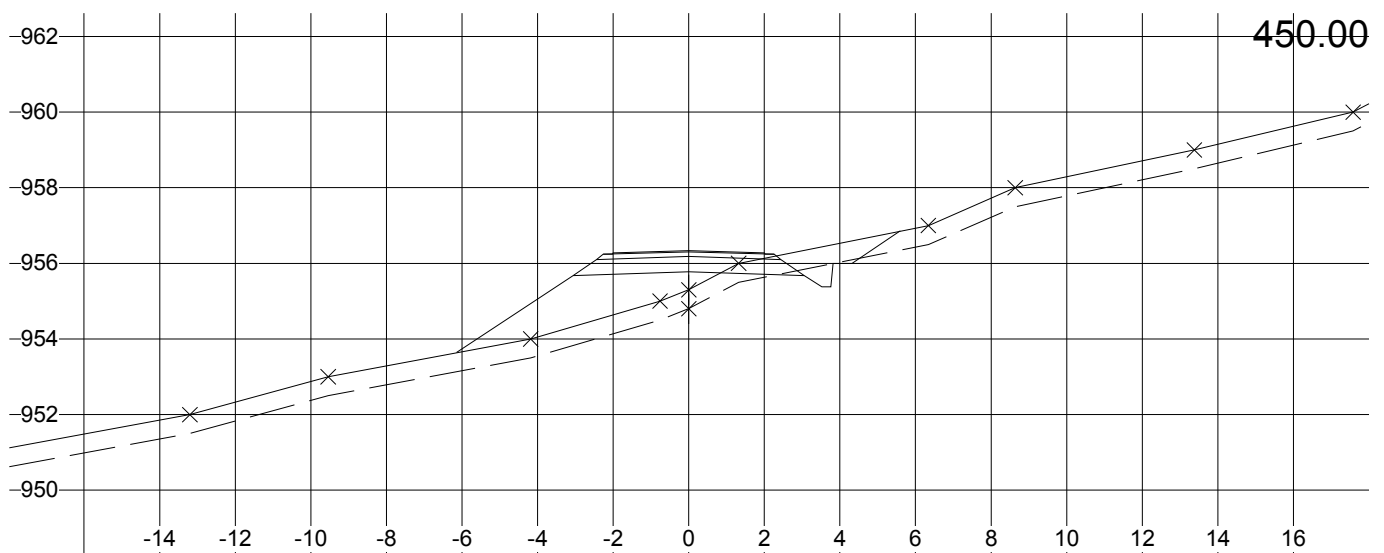
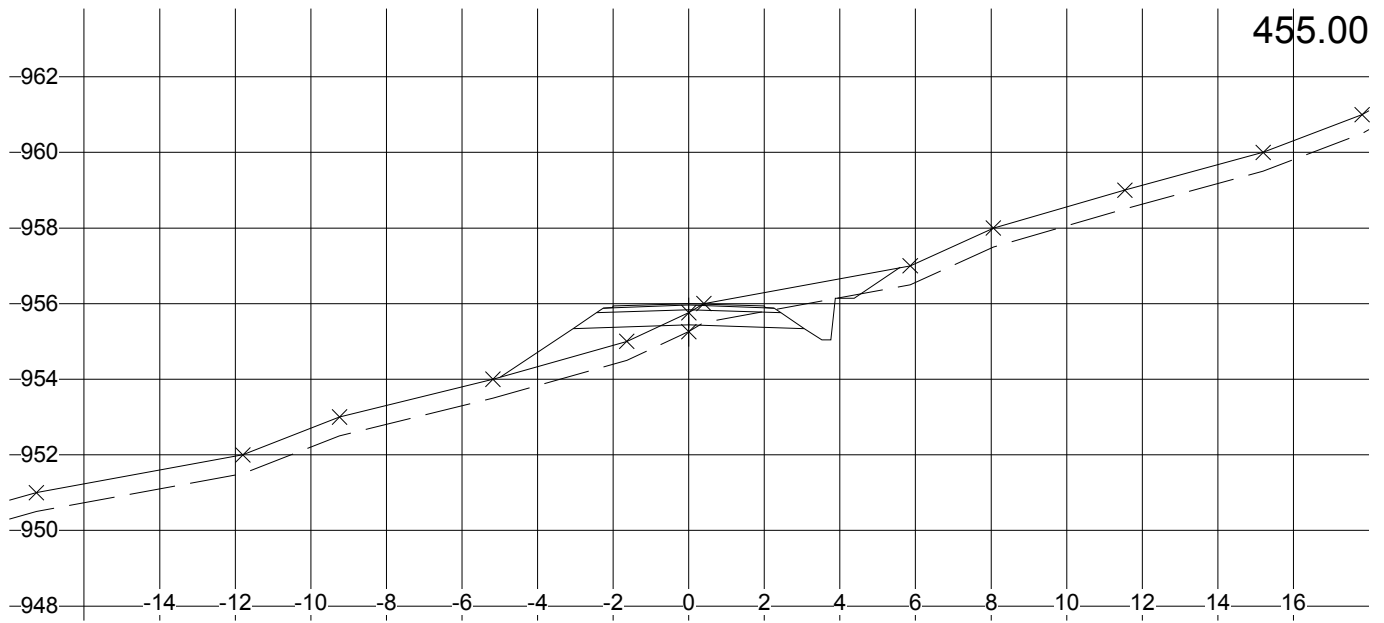

L:\IMA 4.7, Lisens: Plankontoret Hallvard Homme AS, Parsell: Parsell2.psl

Rauland Invest AS Holtarvegen Veg2 Tverrprofil	Tegnet av AST	Saksbehandler
	Sidemannskontr.	Prosjektansvarlig AST
Plankontoret H. Homme AS 4747 Valle Tlf: 37 93 70 00, Fax: 37 93 74 74, E-Post: post@plankontoret.no	Dato 03.12.2009	Målestokk 1: 200
	Prosj.nr. 2219-V2	1: 200
	Tegn.nr. Tp-38	Rev.

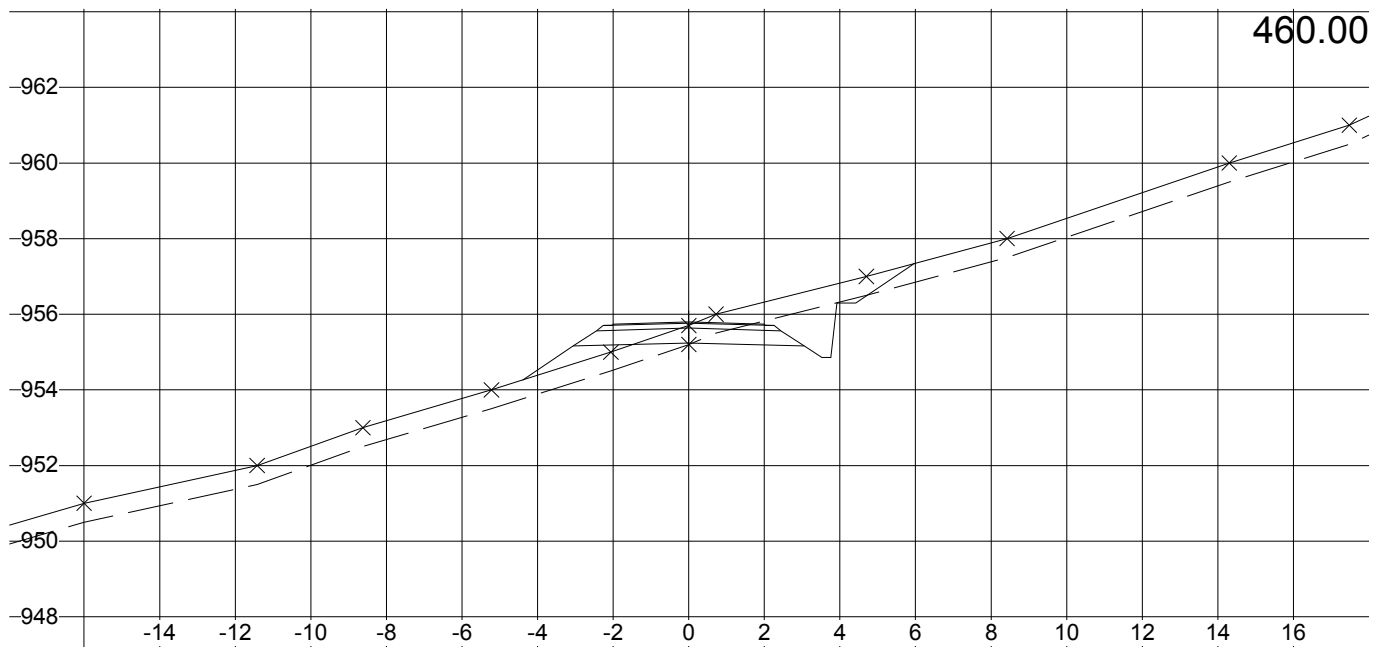
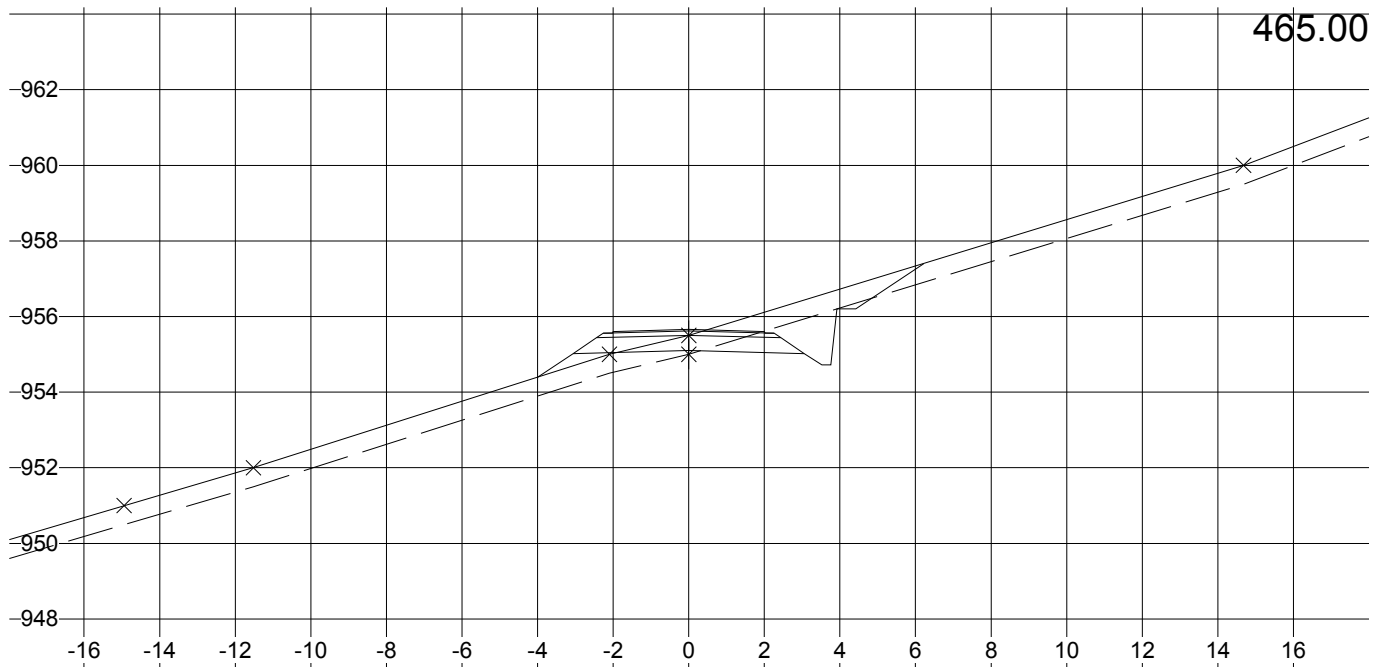

L:\IMA 4.7, Lisens: Plankontoret Hallvard Homme AS, Parsell: Parsell2.psl

Rauland Invest AS Holtarvegen Veg2 Tverrprofil	Tegnet av AST	Saksbehandler
	Sidemannskontr.	Prosjektansvarlig AST
	Dato 03.12.2009	Målestokk 1: 200
	Prosj.nr. 2219-V2	1: 200
Plankontoret H. Homme AS 4747 Valle Tlf: 37 93 70 00, Fax: 37 93 74 74, E-Post: post@plankontoret.no	Tegn.nr. Tp-39	Rev.

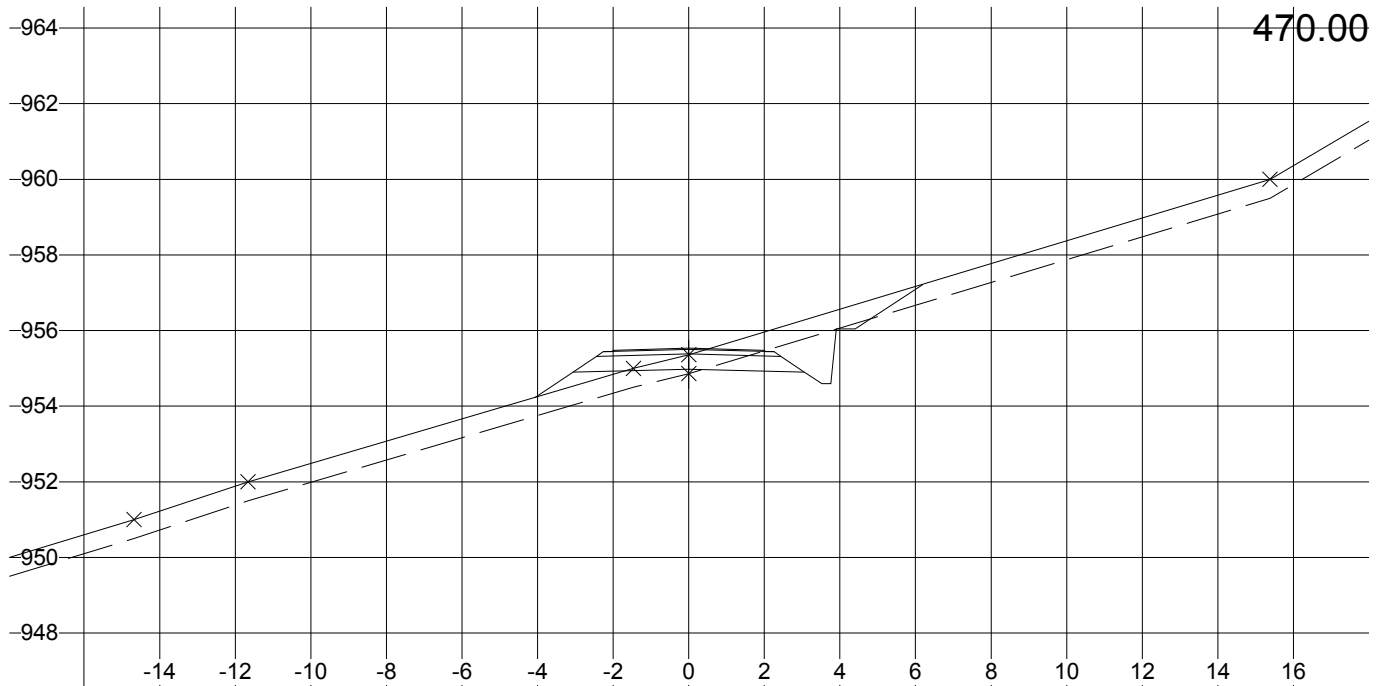
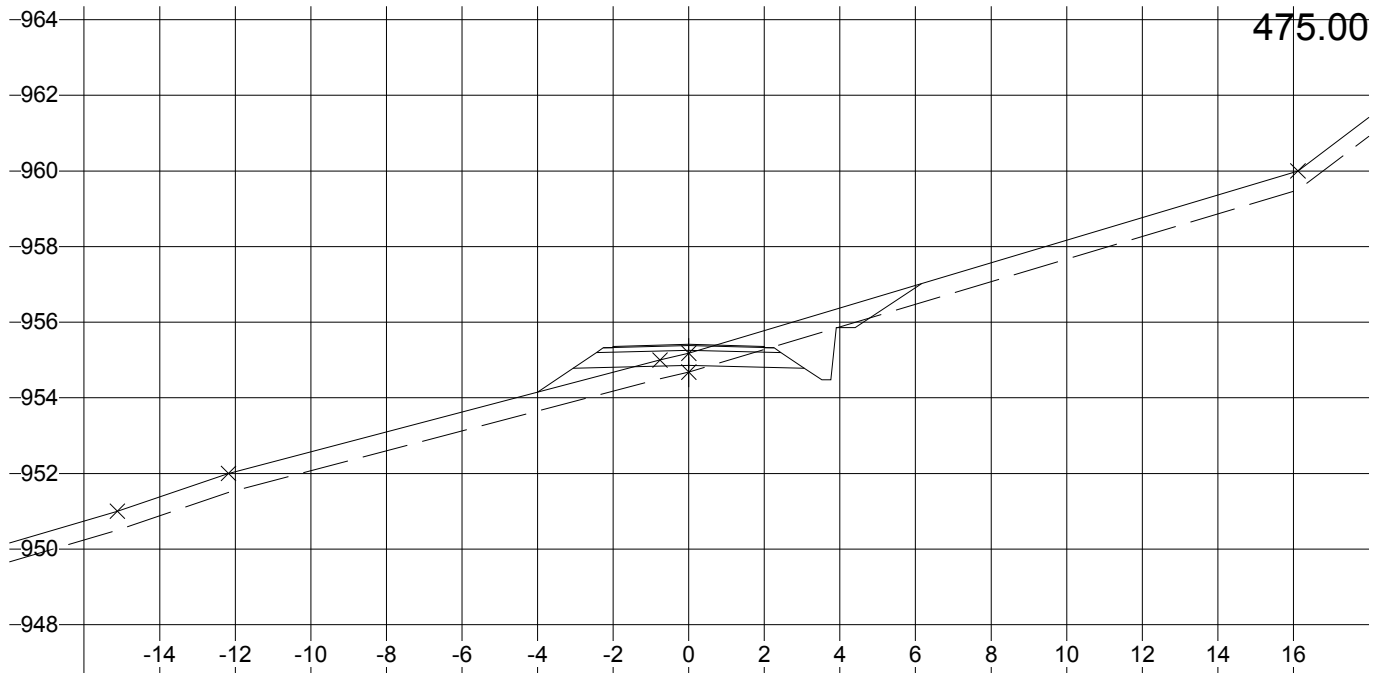

L:\IMA 4.7, Lisens: Plankontoret Hallvard Homme AS, Parsell: Parsell2.psl

Rauland Invest AS Holtarvegen Veg2 Tverrprofil	Tegnet av AST	Saksbehandler
	Sidemannskontr.	Prosjektansvarlig AST
Plankontoret H. Homme AS 4747 Valle Tlf: 37 93 70 00, Fax: 37 93 74 74, E-Post: post@plankontoret.no	Dato 03.12.2009	Målestokk 1: 200
	Prosj.nr. 2219-V2	1: 200
	Tegn.nr. Tp-40	Rev.

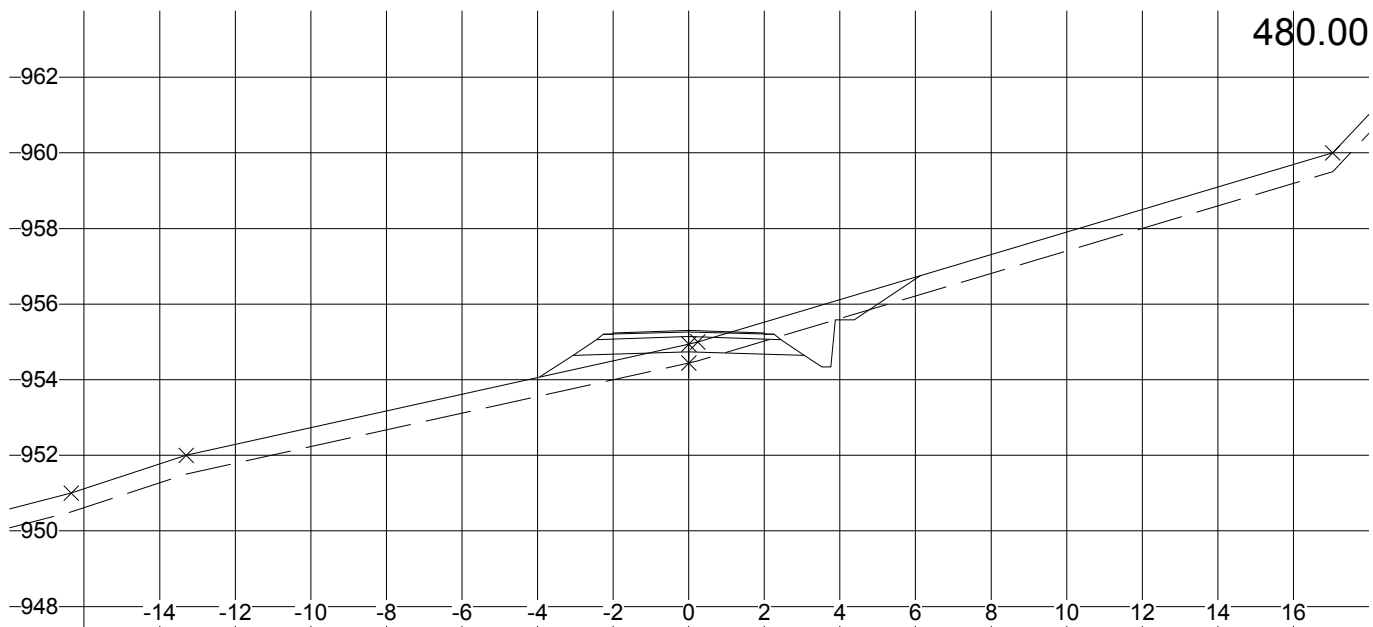
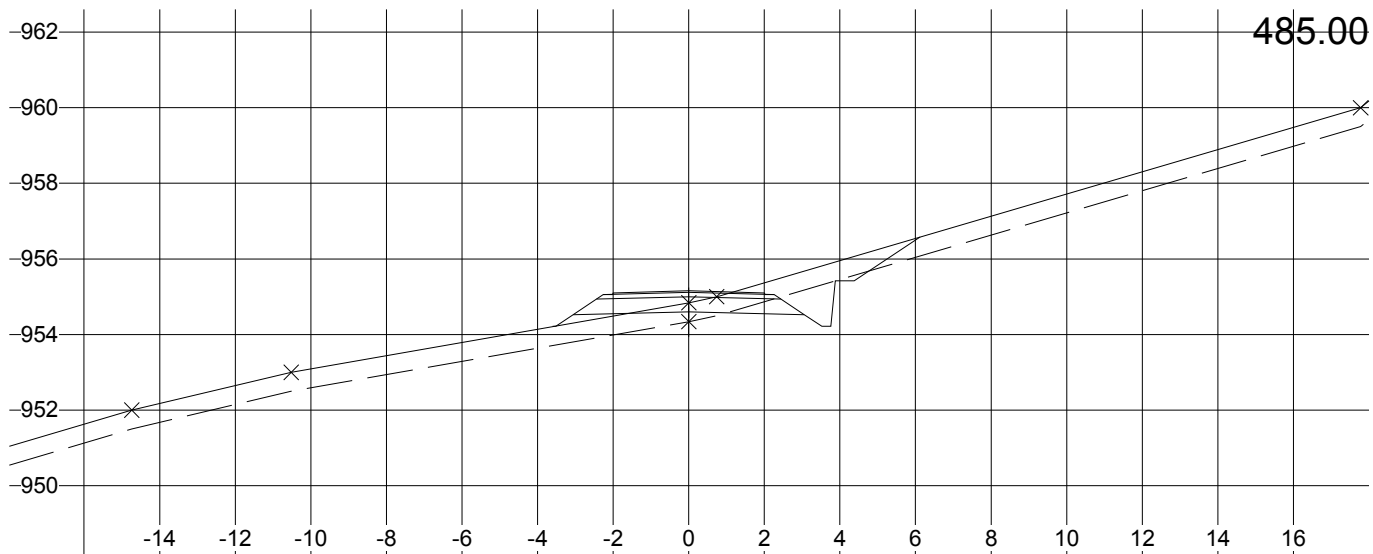

L:\IMA 4.7, Lisens: Plankontoret Hallvard Homme AS, Parsell: Parsell2.psl

Rauland Invest AS Holtarvegen Veg2 Tverrprofil	Tegnet av AST	Saksbehandler
	Sidemannskontr.	Prosjektansvarlig AST
Plankontoret H. Homme AS 4747 Valle Tlf: 37 93 70 00, Fax: 37 93 74 74, E-Post: post@plankontoret.no	Dato 03.12.2009	Målestokk 1: 200
	Prosj.nr. 2219-V2	1: 200
	Tegn.nr. Tp-41	Rev.

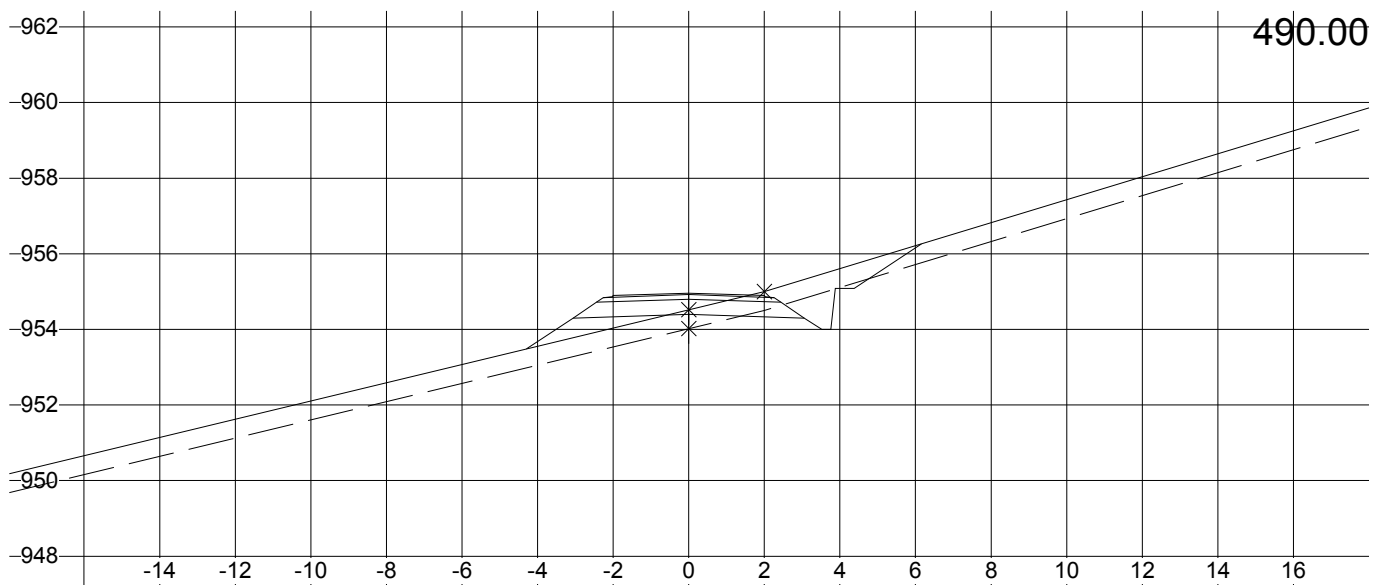
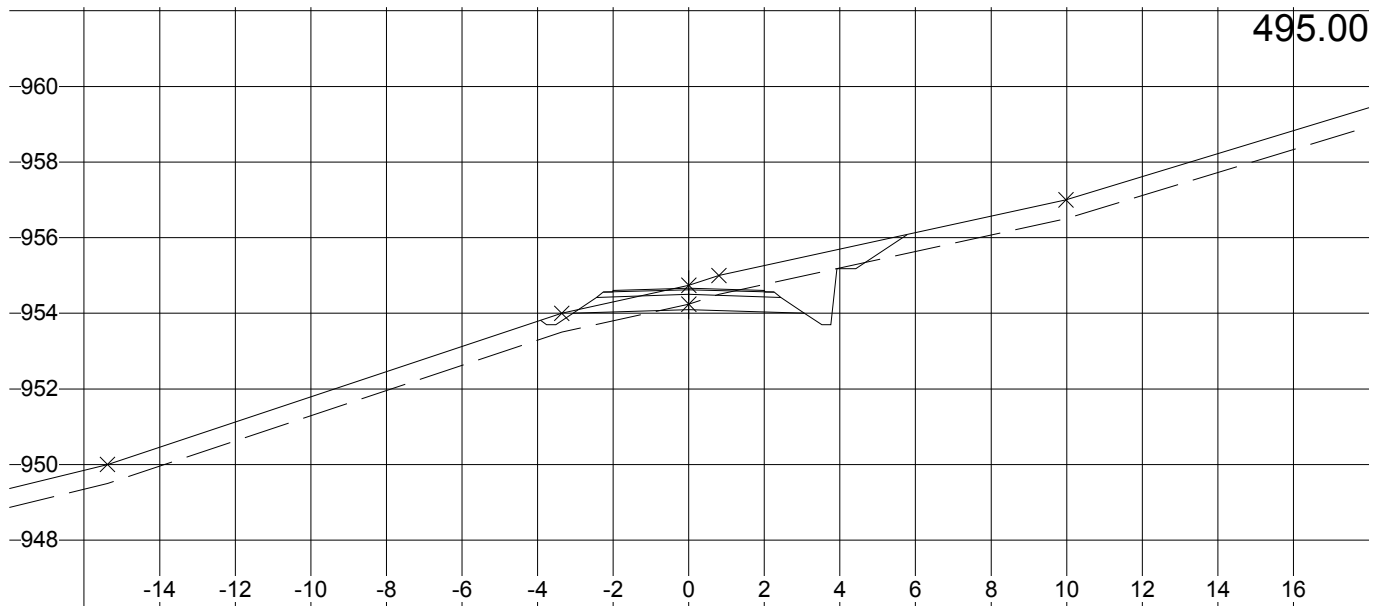

L:\IMA 4.7, Lisens: Plankontoret Hallvard Homme AS, Parsell: Parsell2.psl

Rauland Invest AS Holtarvegen Veg2 Tverrprofil	Tegnet av AST	Saksbehandler
	Sidemannskontr.	Prosjektansvarlig AST
Plankontoret H. Homme AS 4747 Valle Tlf: 37 93 70 00, Fax: 37 93 74 74, E-Post: post@plankontoret.no	Dato 03.12.2009	Målestokk 1: 200
	Prosj.nr. 2219-V2	1: 200
	Tegn.nr. Tp-42	Rev.

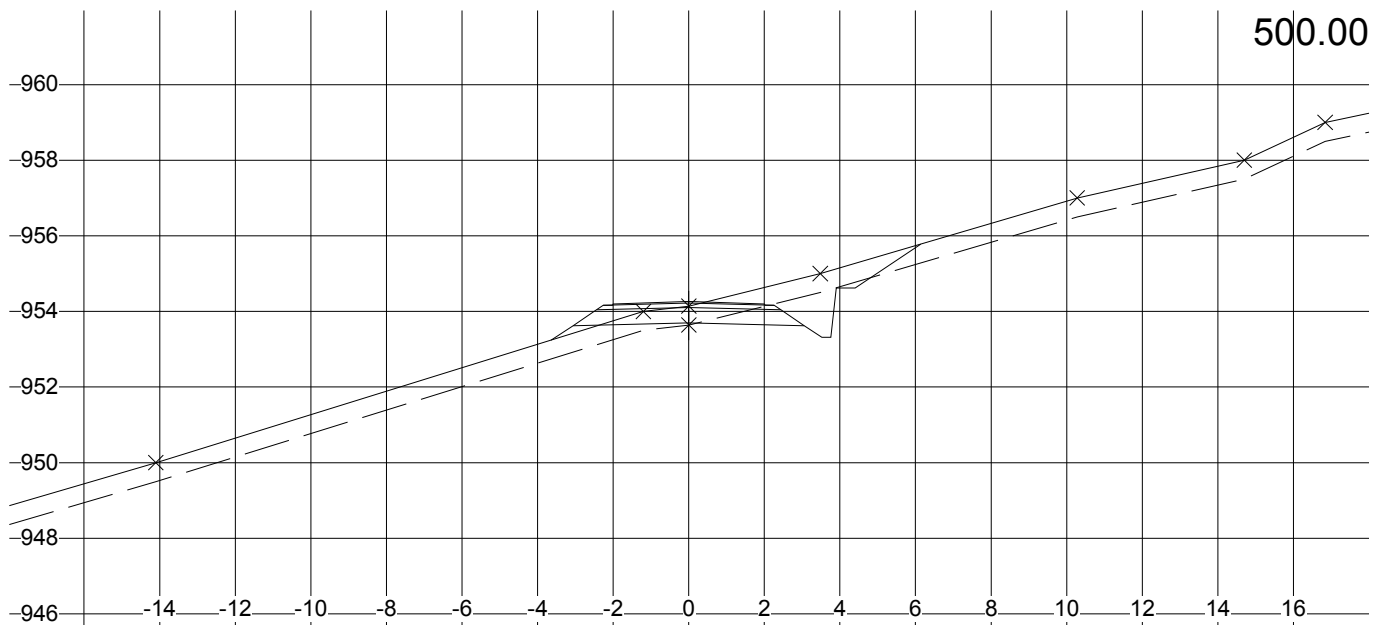
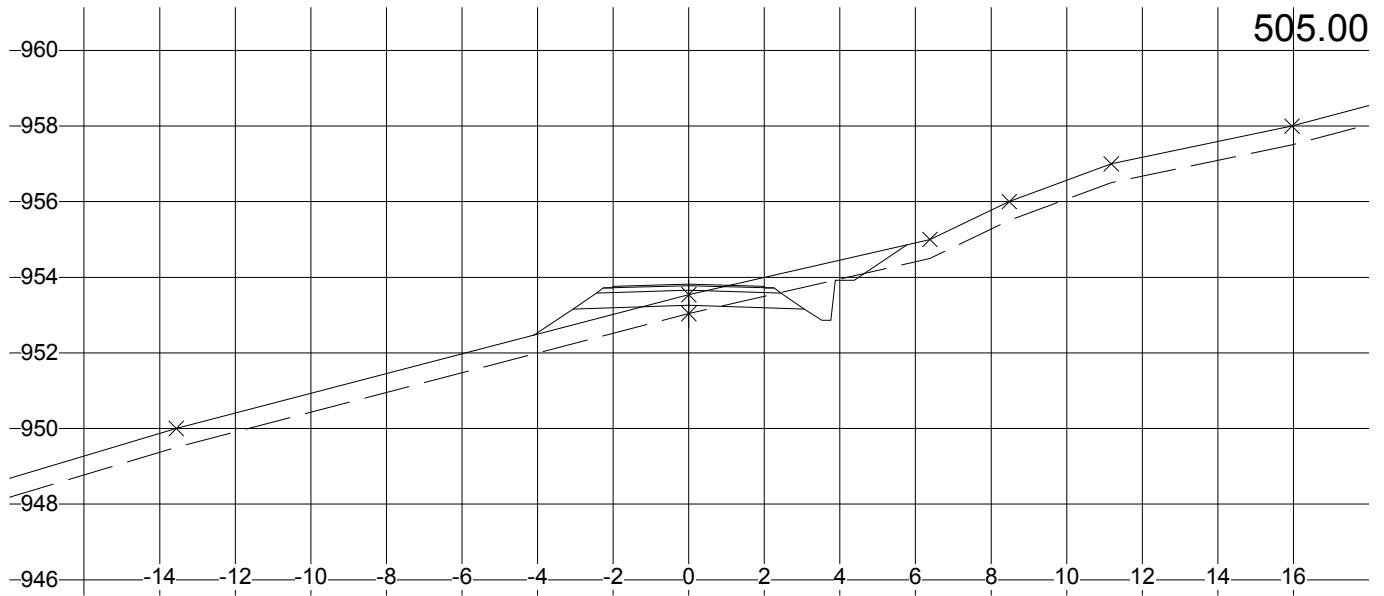

L:\IMA 4.7, Lisens: Plankontoret Hallvard Homme AS, Parsell: Parsell2.psl

Rauland Invest AS Holtarvegen Veg2 Tverrprofil	Tegnet av AST	Saksbehandler
	Sidemannsktr.	Prosjektansvarlig AST
Plankontoret H. Homme AS 4747 Valle Tlf: 37 93 70 00, Fax: 37 93 74 74, E-Post: post@plankontoret.no	Dato 03.12.2009	Målestokk 1: 200
	Prosj.nr. 2219-V2	1: 200
	Tegn.nr. Tp-43	Rev.

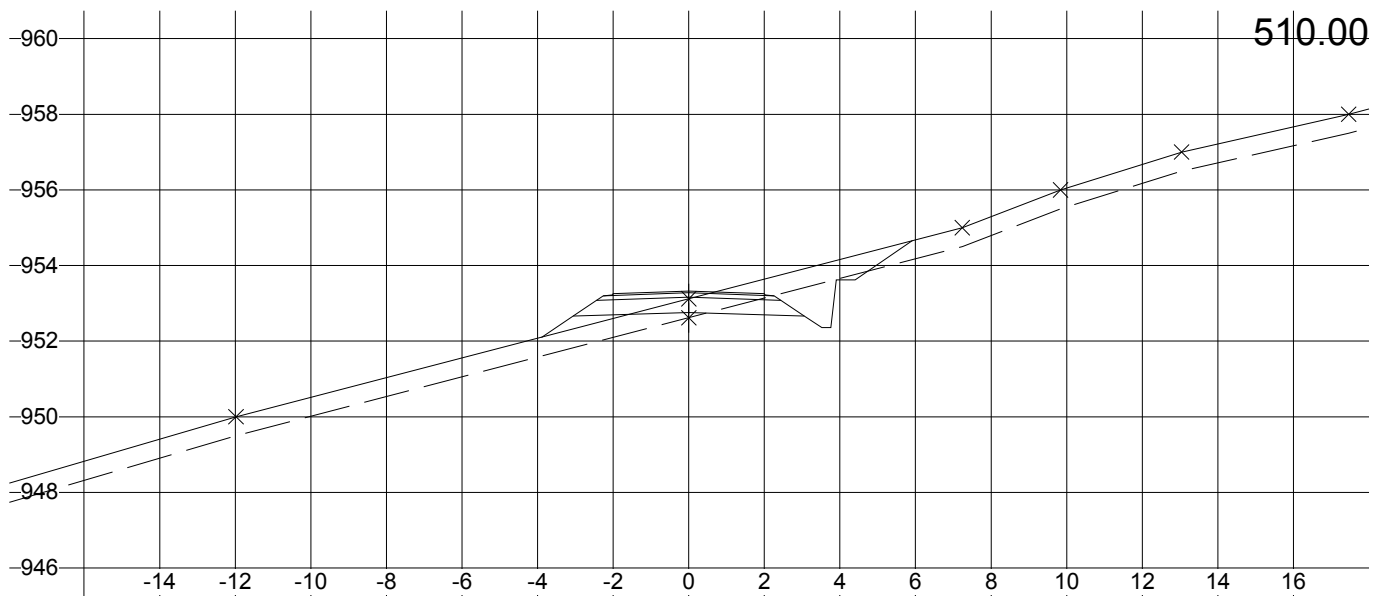
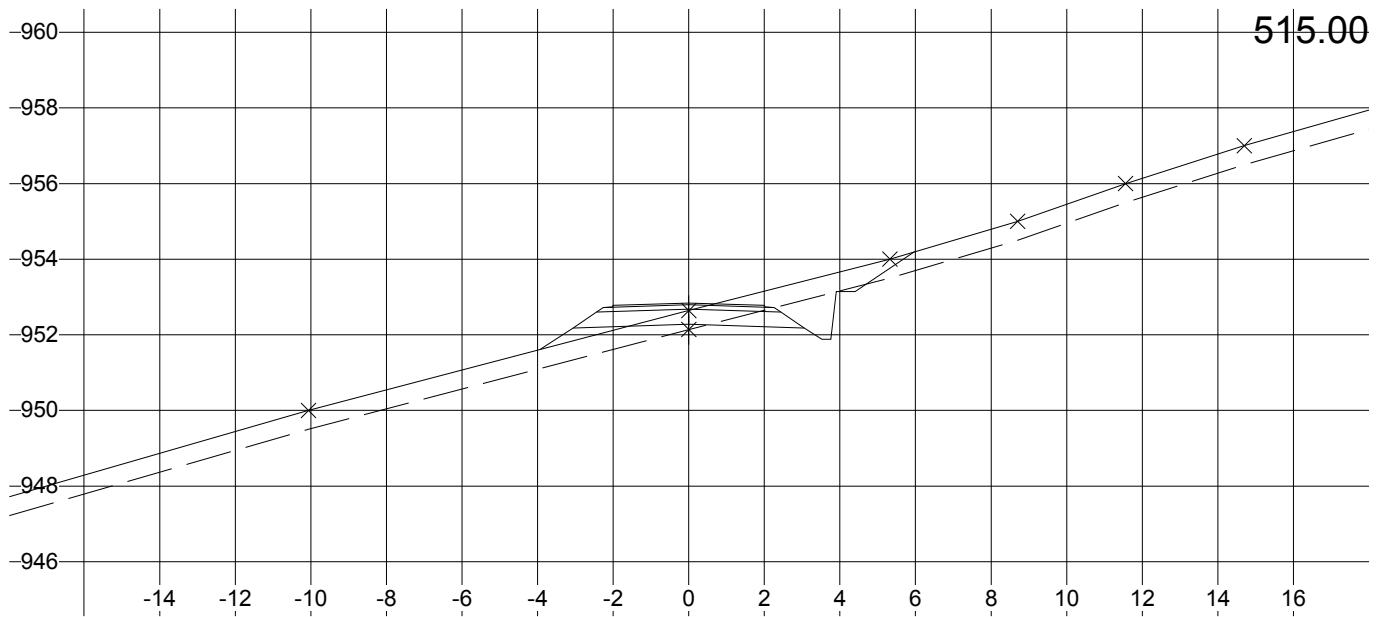

L:\IMA 4.7, Lisens: Plankontoret Hallvard Homme AS, Parsell: Parsell2.psl

Rauland Invest AS Holtarvegen Veg2 Tverrprofil	Tegnet av AST	Saksbehandler
	Sidemannskontr.	Prosjektansvarlig AST
Plankontoret H. Homme AS 4747 Valle Tlf: 37 93 70 00, Fax: 37 93 74 74, E-Post: post@plankontoret.no	Dato 03.12.2009	Målestokk 1: 200
	Prosj.nr. 2219-V2	1: 200
	Tegn.nr. Tp-44	Rev.

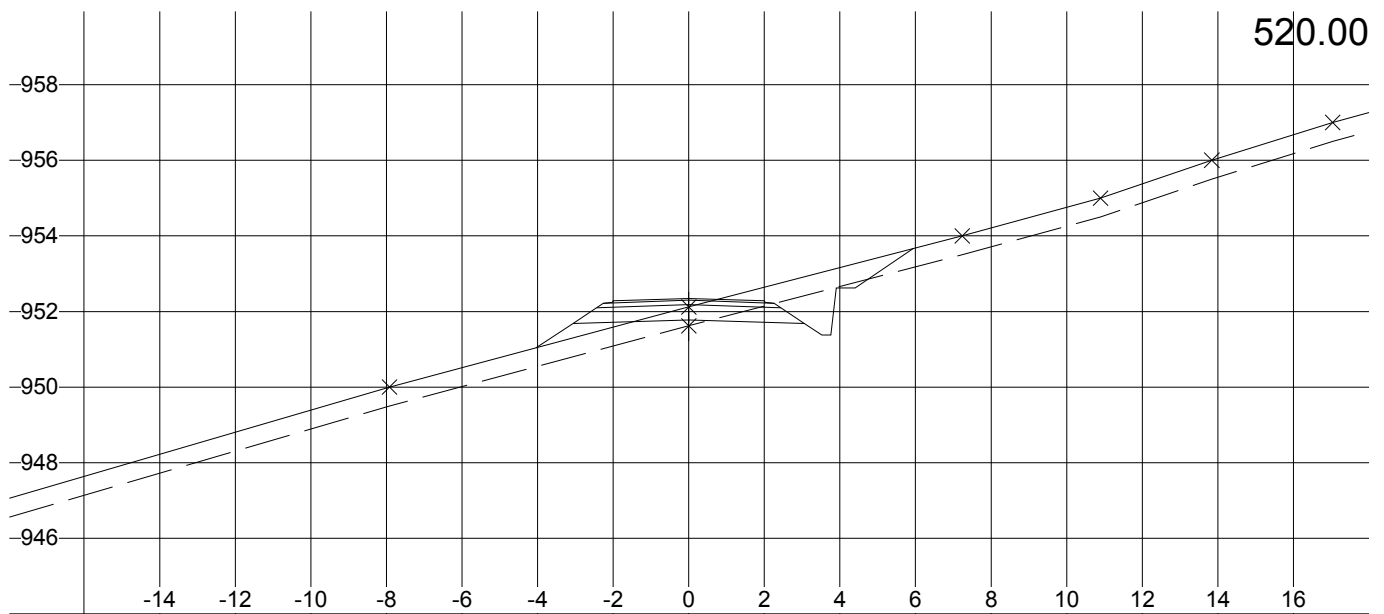
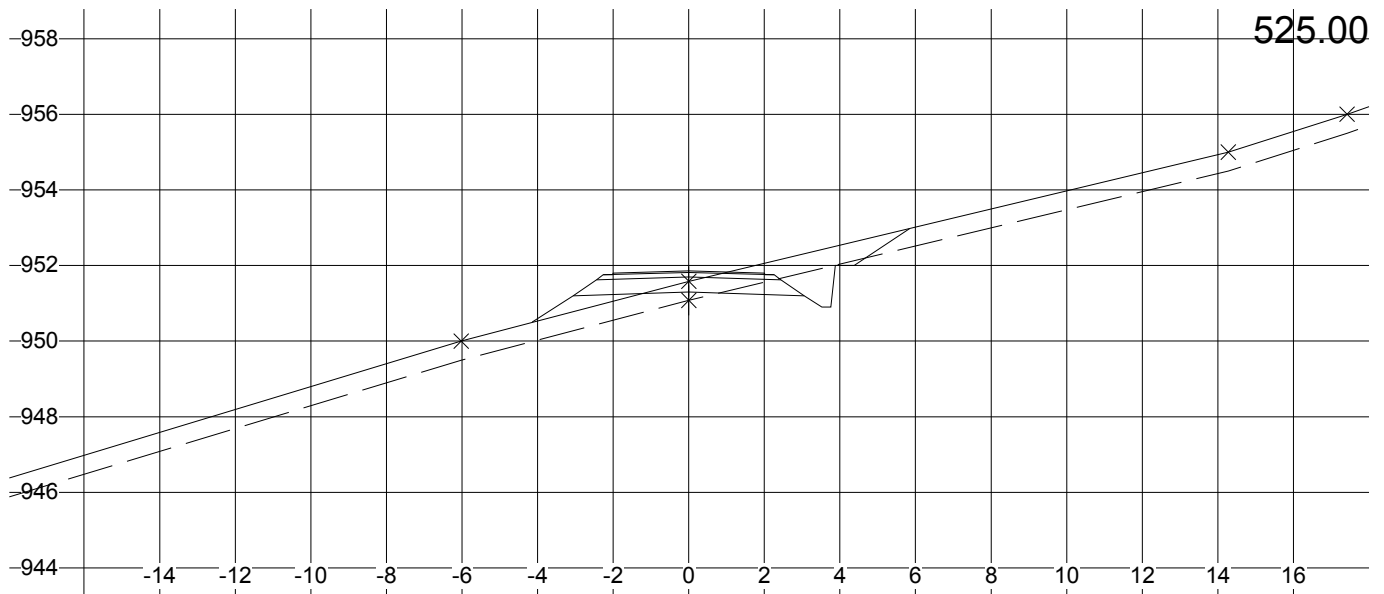

L:\IMA 4.7, Lisens: Plankontoret Hallvard Homme AS, Parsell: Parsell2.psl

Rauland Invest AS Holtarvegen Veg2 Tverrprofil	Tegnet av AST	Saksbehandler
	Sidemannskontr.	Prosjektansvarlig AST
Plankontoret H. Homme AS 4747 Valle Tlf: 37 93 70 00, Fax: 37 93 74 74, E-Post: post@plankontoret.no	Dato 03.12.2009	Målestokk 1: 200
	Prosj.nr. 2219-V2	1: 200
	Tegn.nr. Tp-45	Rev.

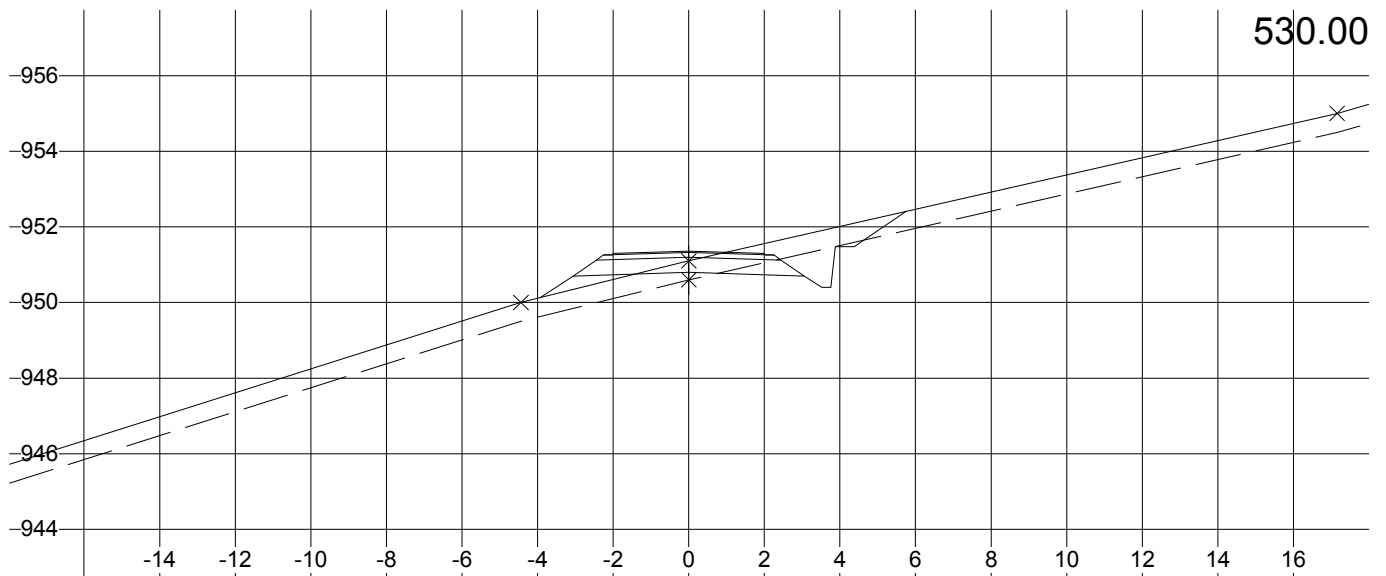
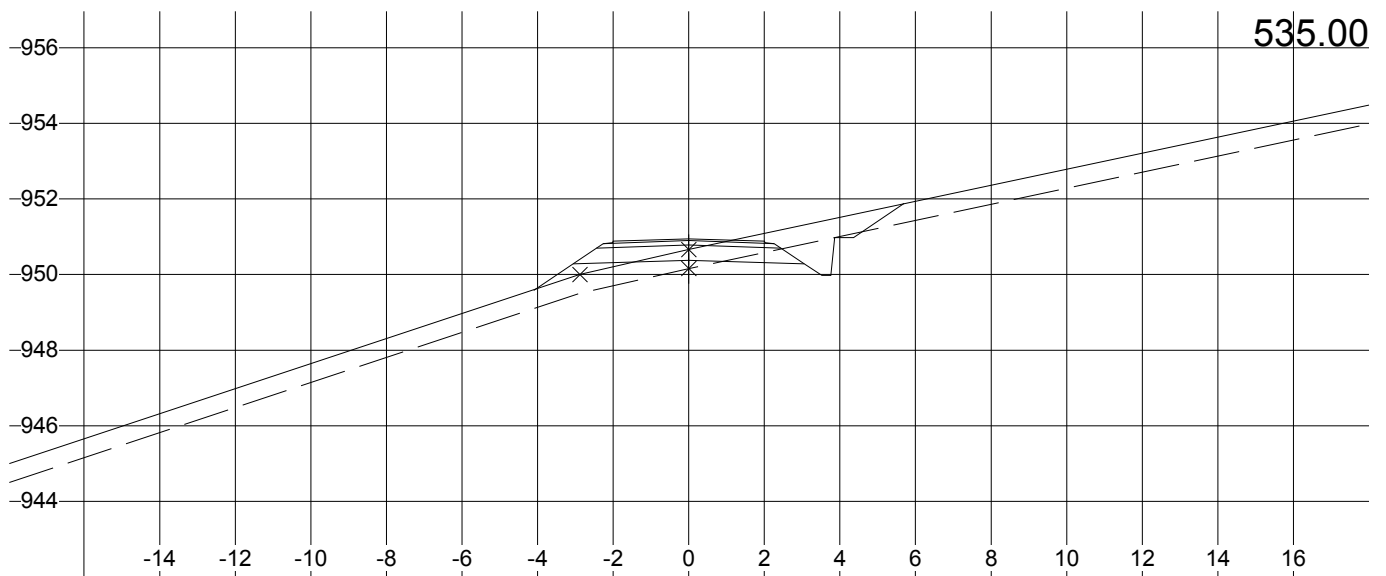

L:\IMA 4.7, Lisens: Plankontoret Hallvard Homme AS, Parsell: Parsell2.psl

Rauland Invest AS Holtarvegen Veg2 Tverrprofil	Tegnet av AST	Saksbehandler
	Sidemannskontr.	Prosjektansvarlig AST
Plankontoret H. Homme AS 4747 Valle Tlf: 37 93 70 00, Fax: 37 93 74 74, E-Post: post@plankontoret.no	Dato 03.12.2009	Målestokk 1: 200
	Prosj.nr. 2219-V2	1: 200
	Tegn.nr. Tp-46	Rev.

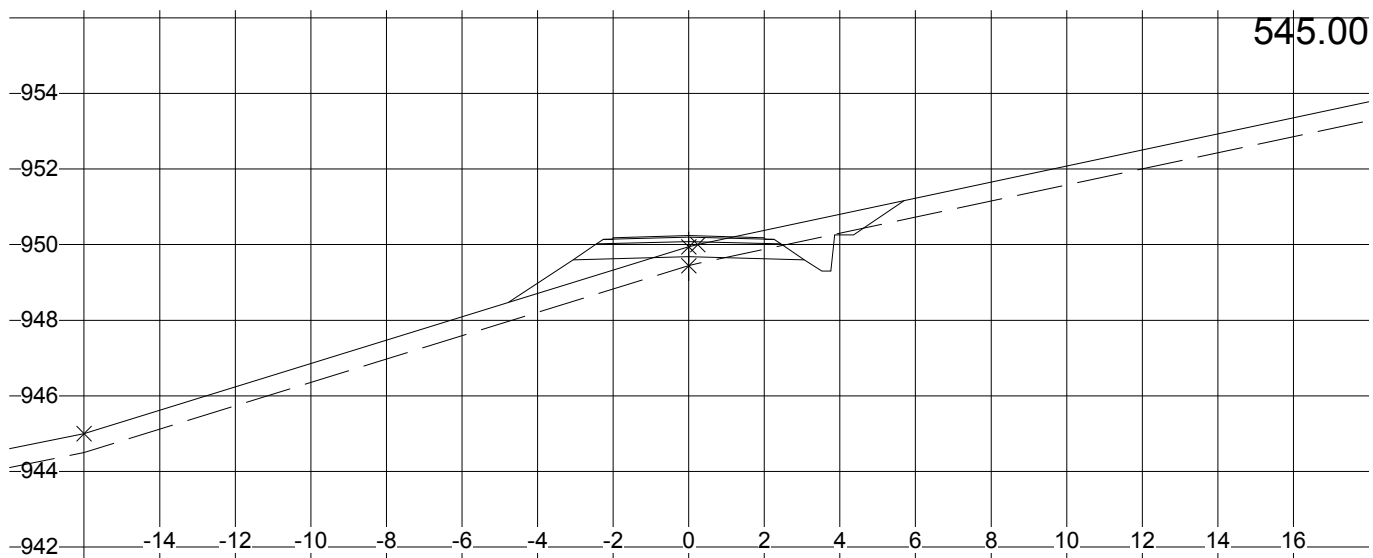

545.00

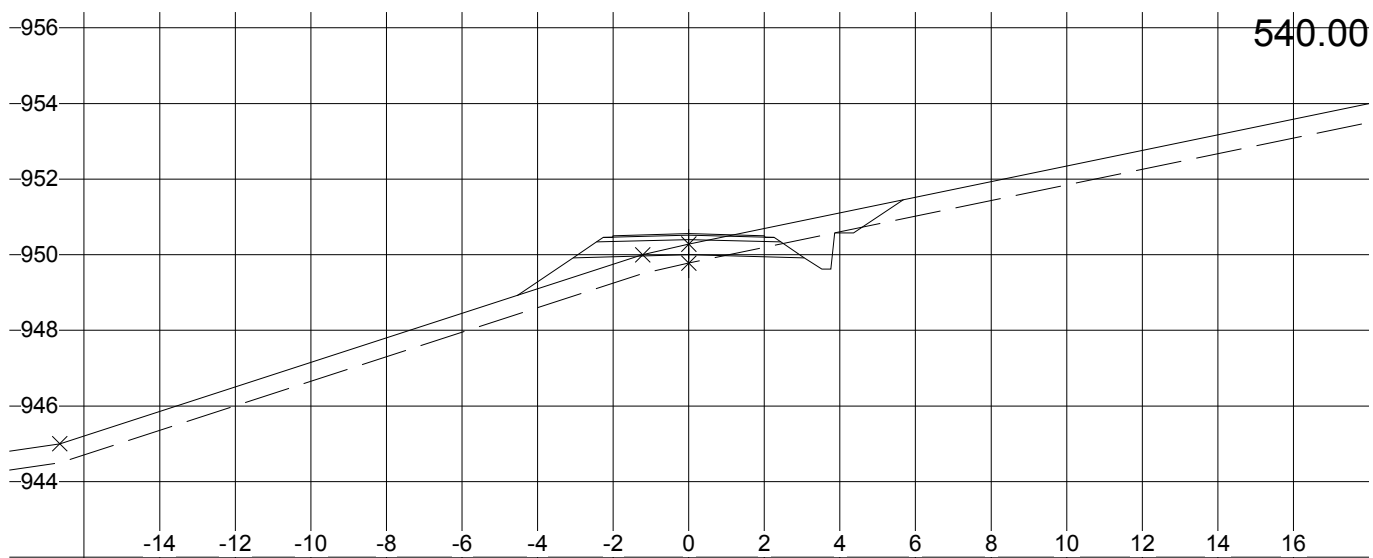

540.00

L:\IMA 4.7, Lisens: Plankontoret Hallvard Homme AS, Parsell: Parsell2.psl

Rauland Invest AS Holtarvegen Veg2 Tverrprofil	Tegnet av AST	Saksbehandler
	Sidemannskontr.	Prosjektansvarlig AST
	Dato 03.12.2009	Målestokk 1: 200 1: 200
	Prosj.nr. 2219-V2	Rev.
Plankontoret H. Homme AS 4747 Valle Tlf: 37 93 70 00, Fax: 37 93 74 74, E-Post: post@plankontoret.no	Tegn.nr. Tp-47	

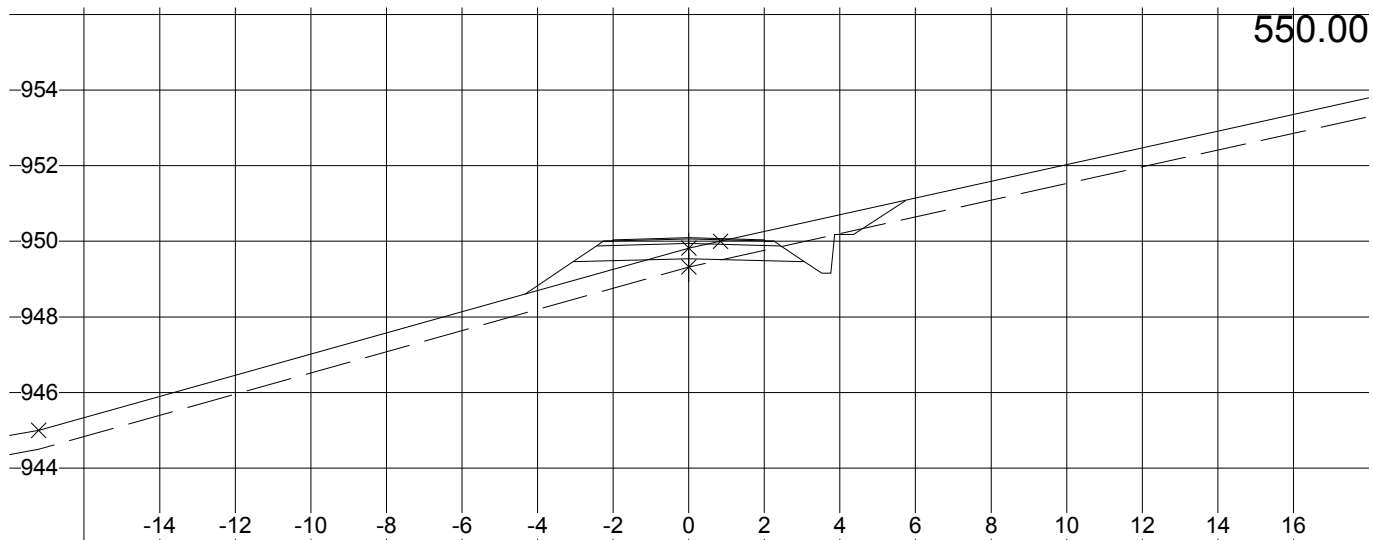
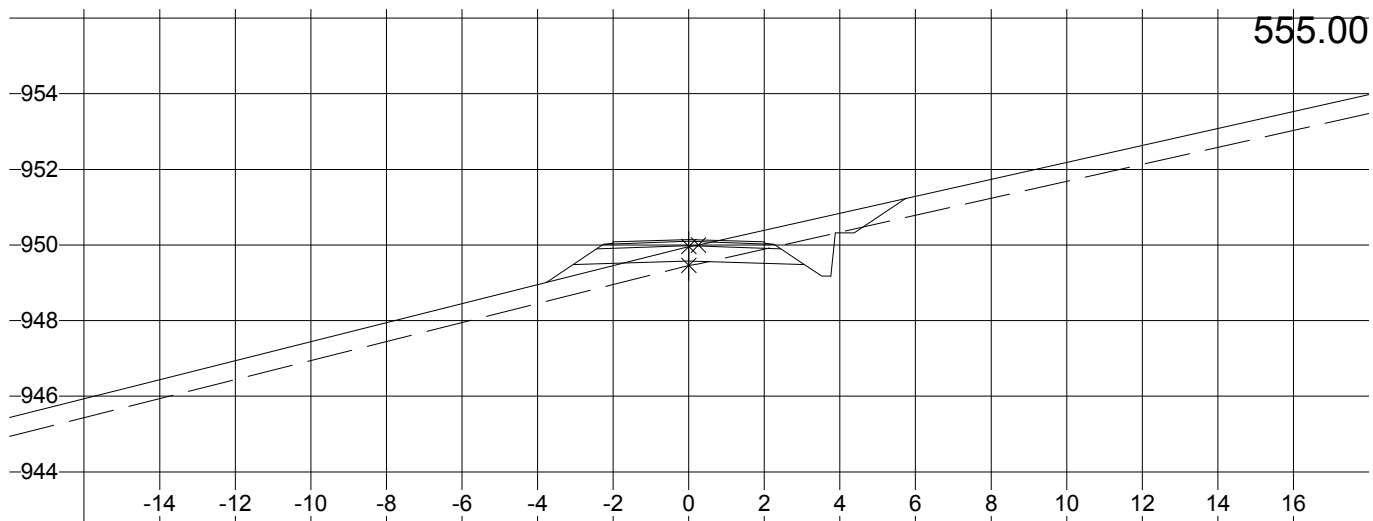
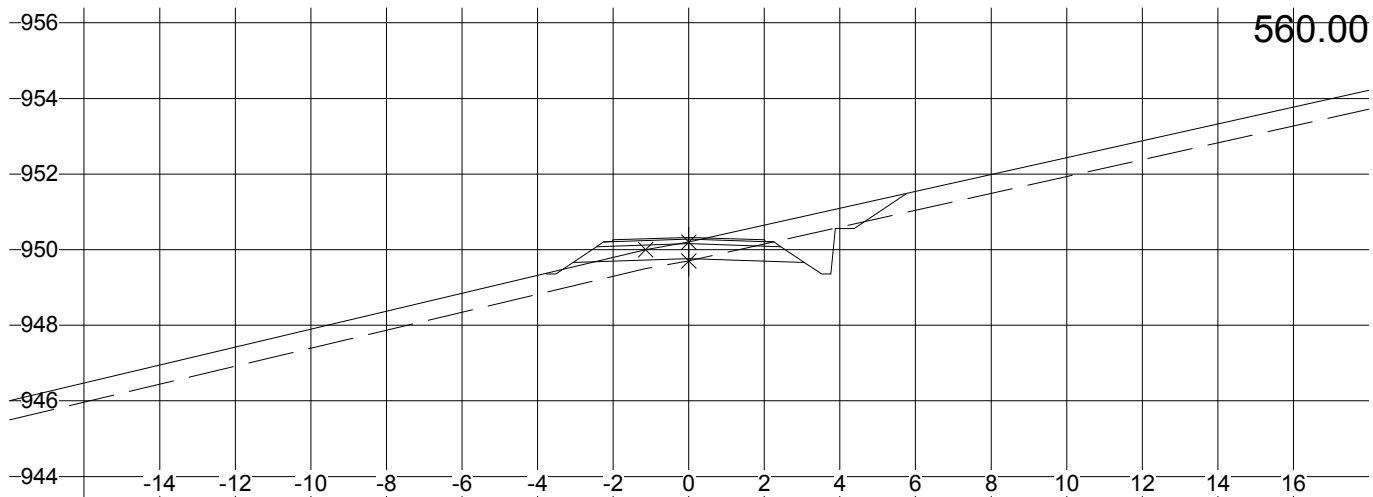

L:\IMA 4.7, Lisens: Plankontoret Hallvard Homme AS, Parsell: Parsell2.psl

Rauland Invest AS Holtarvegen Veg2 Tverrprofil	Tegnet av AST	Saksbehandler
	Sidemannskontr.	Prosjektansvarlig AST
Plankontoret H. Homme AS 4747 Valle Tlf: 37 93 70 00, Fax: 37 93 74 74, E-Post: post@plankontoret.no	Dato 03.12.2009	Målestokk 1: 200
	Prosj.nr. 2219-V2	1: 200
	Tegn.nr. Tp-48	Rev.

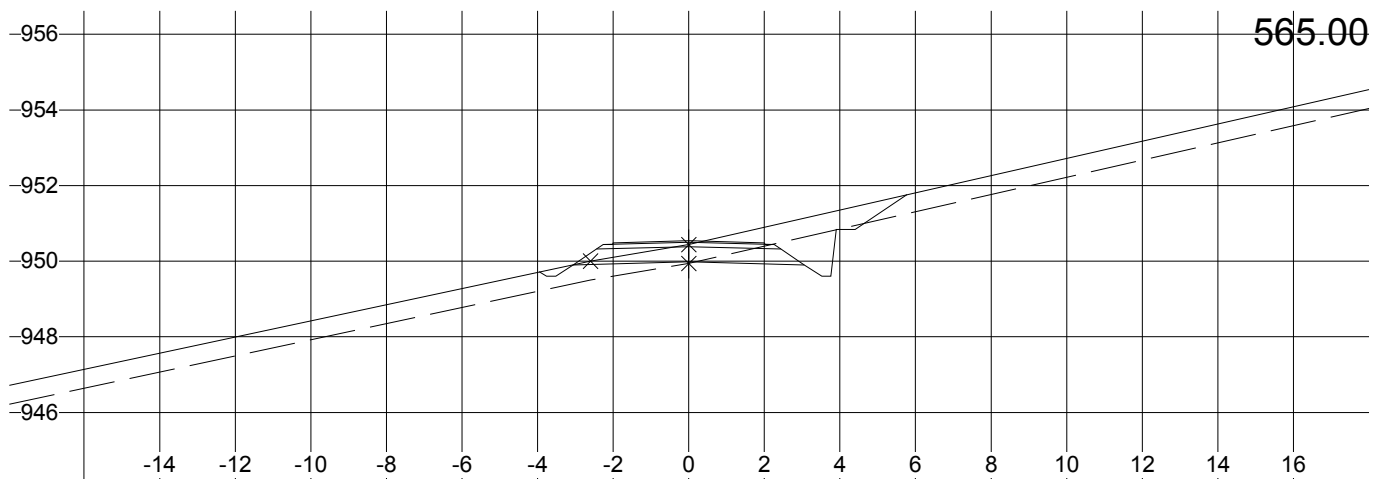
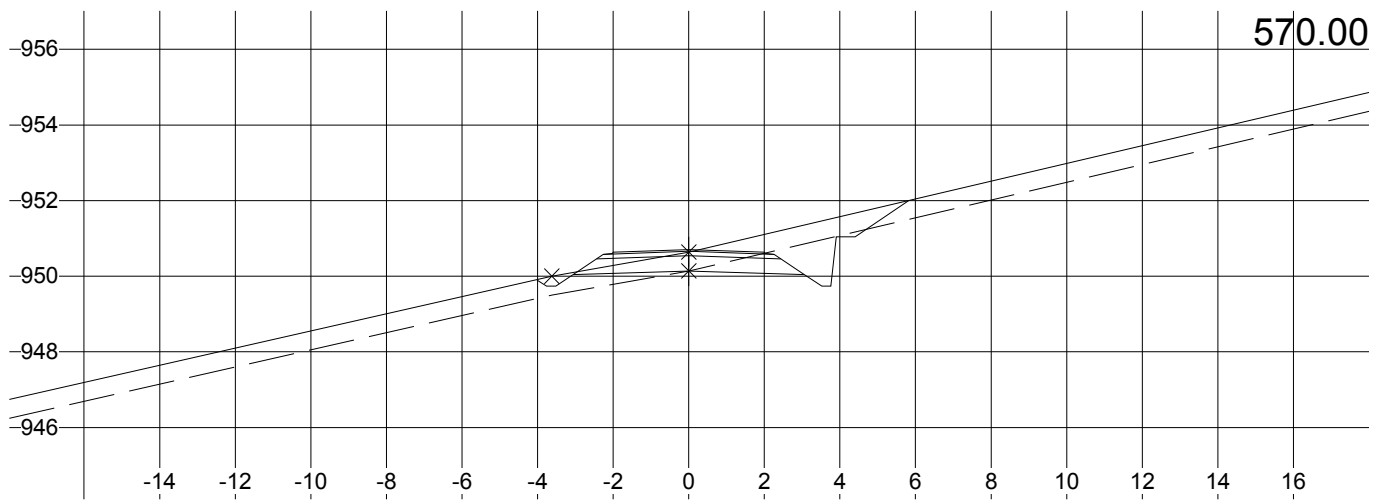
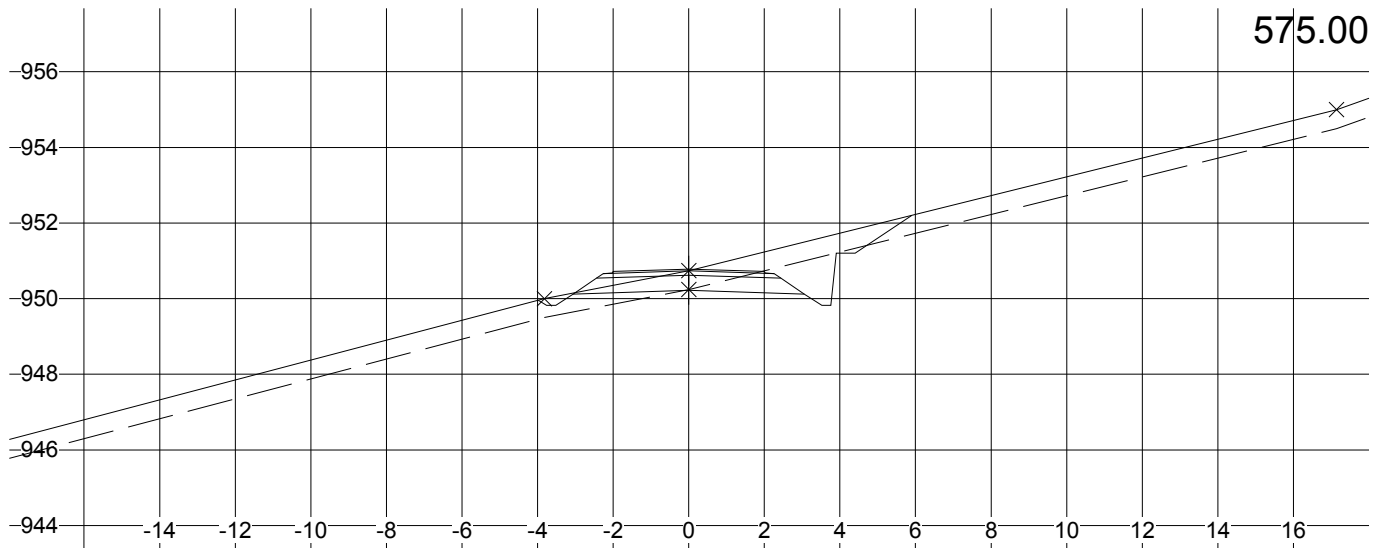

L:\IMA 4.7, Lisens: Plankontoret Hallvard Homme AS, Parsell: Parsell2.psl

Rauland Invest AS Holtarvegen Veg2 Tverrprofil	Tegnet av AST	Saksbehandler
	Sidemannskontroll.	Prosjektansvarlig AST
	Dato 03.12.2009	Målestokk 1: 200
	Prosj.nr. 2219-V2	1: 200
Plankontoret H. Homme AS 4747 Valle Tlf: 37 93 70 00, Fax: 37 93 74 74, E-Post: post@plankontoret.no	Tegn.nr. Tp-49	Rev.

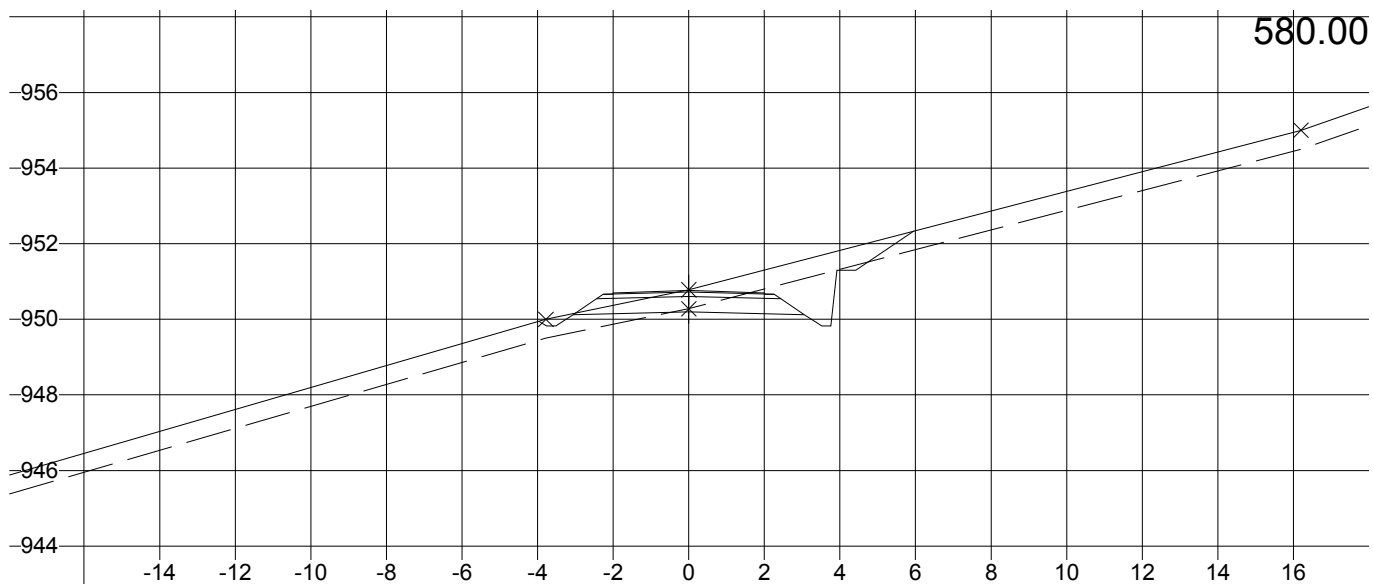
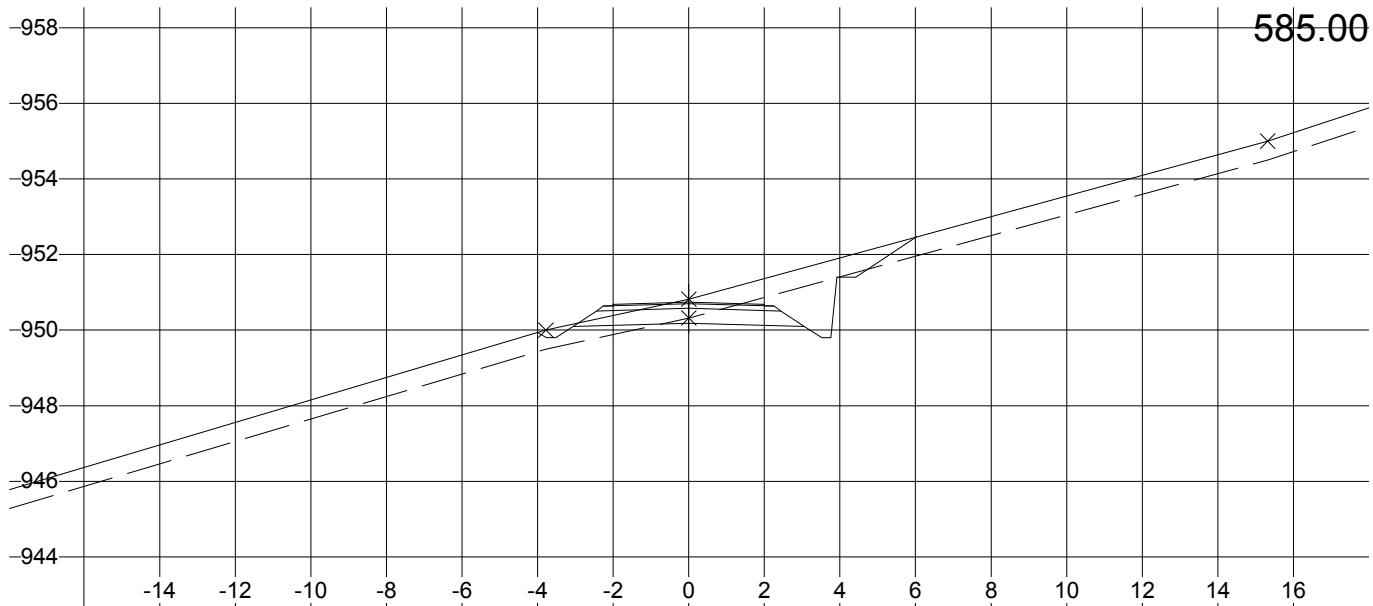

L:\IMA 4.7, Lisens: Plankontoret Hallvard Homme AS, Parsell: Parsell2.psl

Rauland Invest AS Holtarvegen Veg2 Tverrprofil	Tegnet av AST	Saksbehandler
	Sidemannskontr.	Prosjektansvarlig AST
Plankontoret H. Homme AS 4747 Valle Tlf: 37 93 70 00, Fax: 37 93 74 74, E-Post: post@plankontoret.no	Dato 03.12.2009	Målestokk 1: 200
	Prosj.nr. 2219-V2	1: 200
	Tegn.nr. Tp-50	Rev.

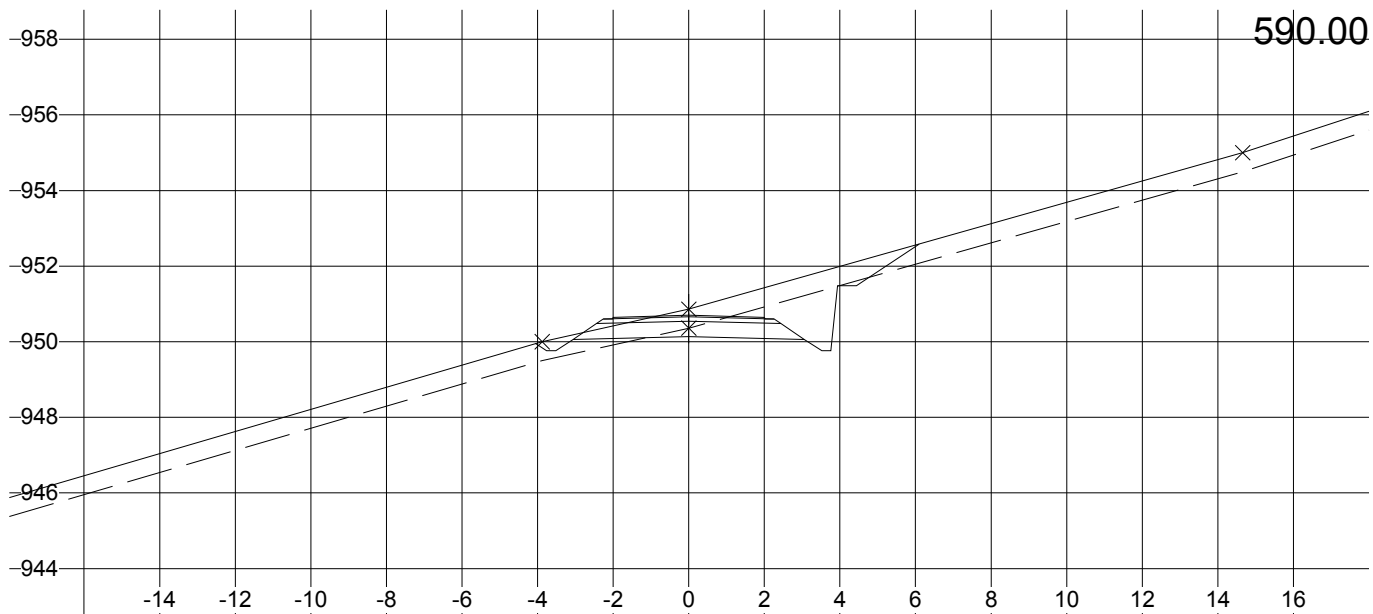
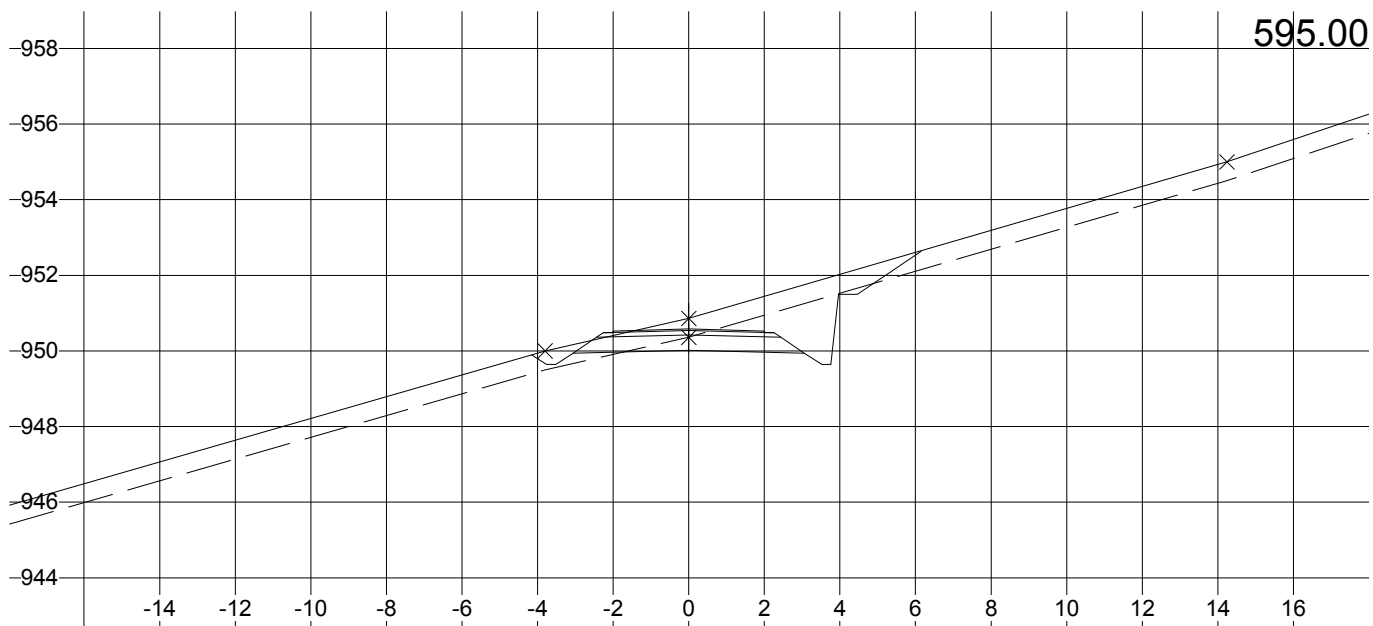

L:\IMA 4.7, Lisens: Plankontoret Hallvard Homme AS, Parsell: Parsell2.psl

Rauland Invest AS Holtarvegen Veg2 Tverrprofil	Tegnet av AST	Saksbehandler
	Sidemannskontr.	Prosjektansvarlig AST
Plankontoret H. Homme AS 4747 Valle Tlf: 37 93 70 00, Fax: 37 93 74 74, E-Post: post@plankontoret.no	Dato 03.12.2009	Målestokk 1: 200
	Prosj.nr. 2219-V2	1: 200
	Tegn.nr. Tp-51	Rev.

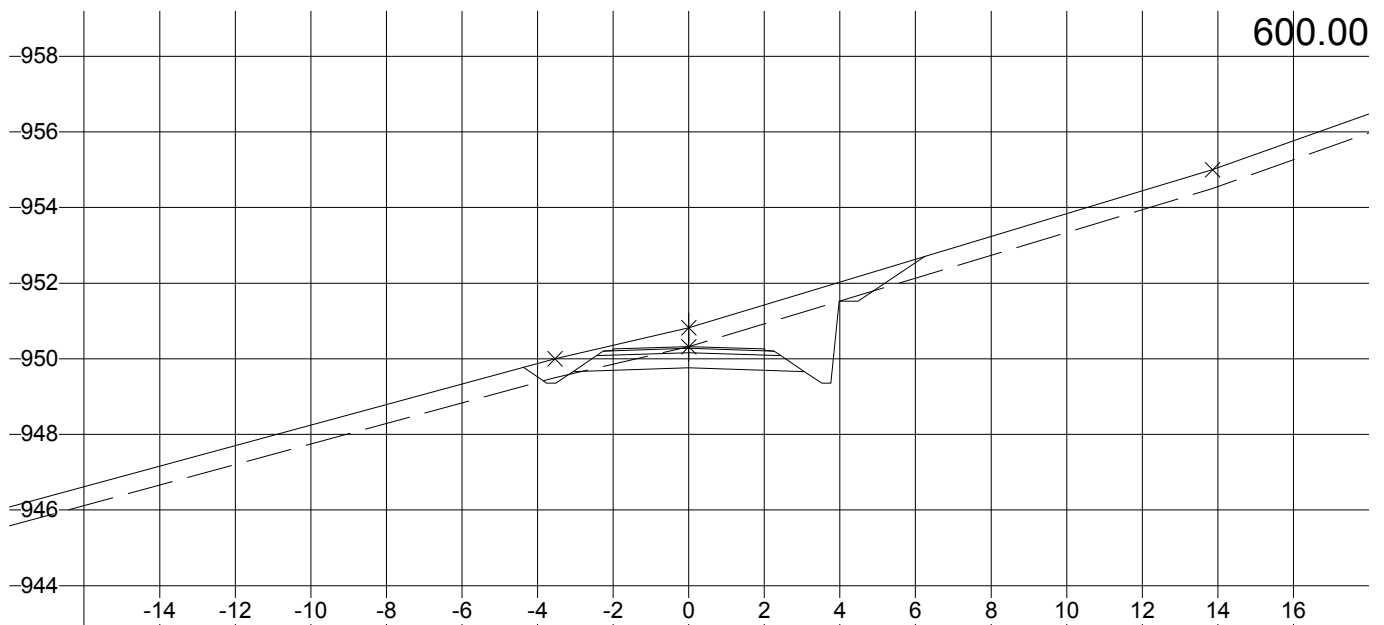
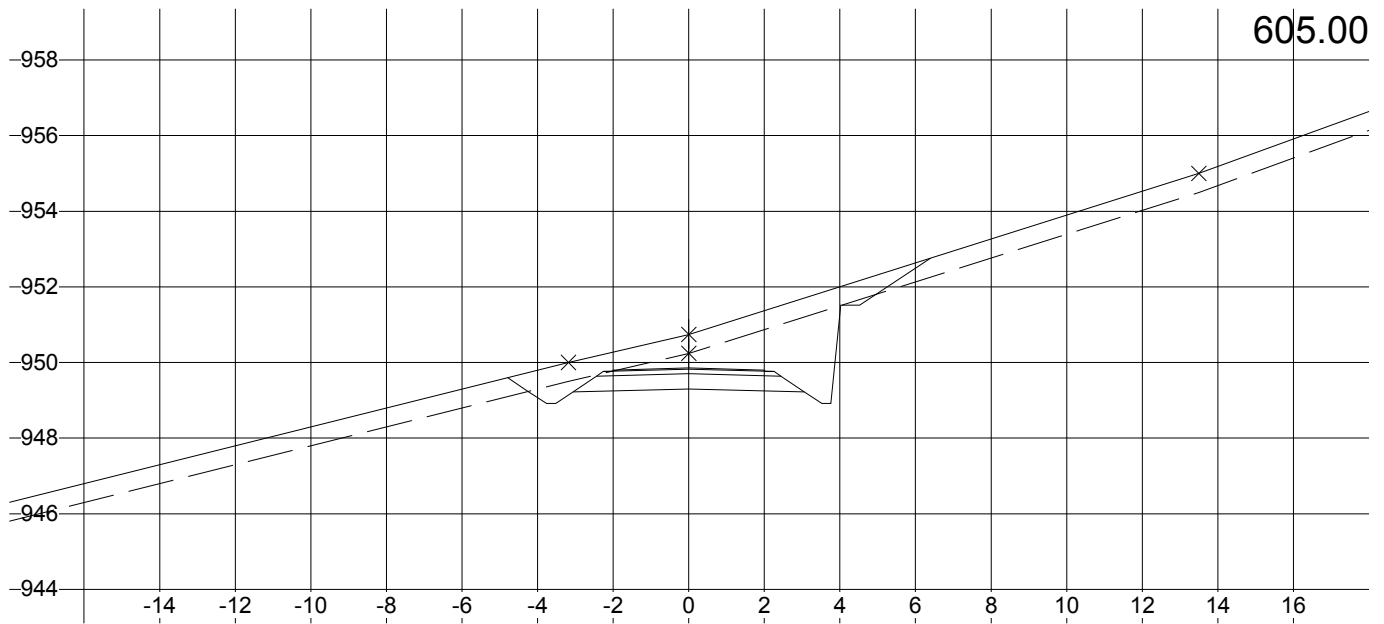

L:\IMA 4.7, Lisens: Plankontoret Hallvard Homme AS, Parsell: Parsell2.psl

Rauland Invest AS Holtarvegen Veg2 Tverrprofil	Tegnet av AST	Saksbehandler
	Sidemannskontr.	Prosjektansvarlig AST
Plankontoret H. Homme AS 4747 Valle Tlf: 37 93 70 00, Fax: 37 93 74 74, E-Post: post@plankontoret.no	Dato 03.12.2009	Målestokk 1: 200
	Prosj.nr. 2219-V2	1: 200
	Tegn.nr. Tp-52	Rev.

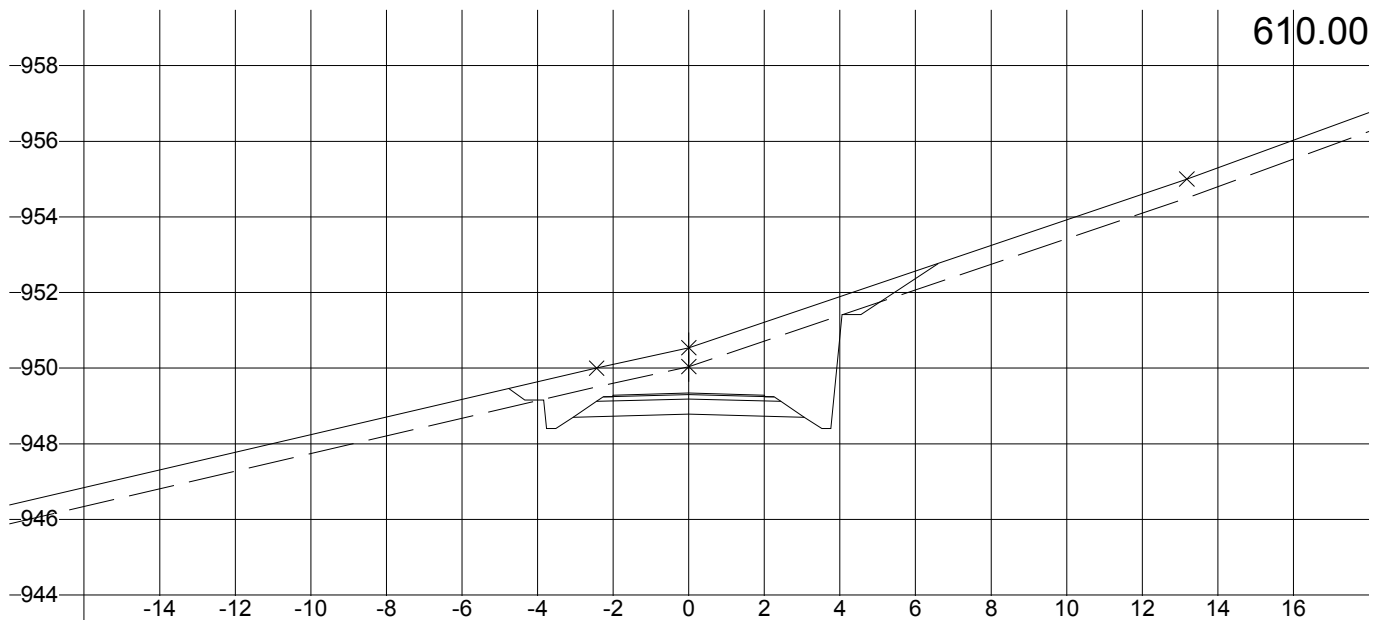
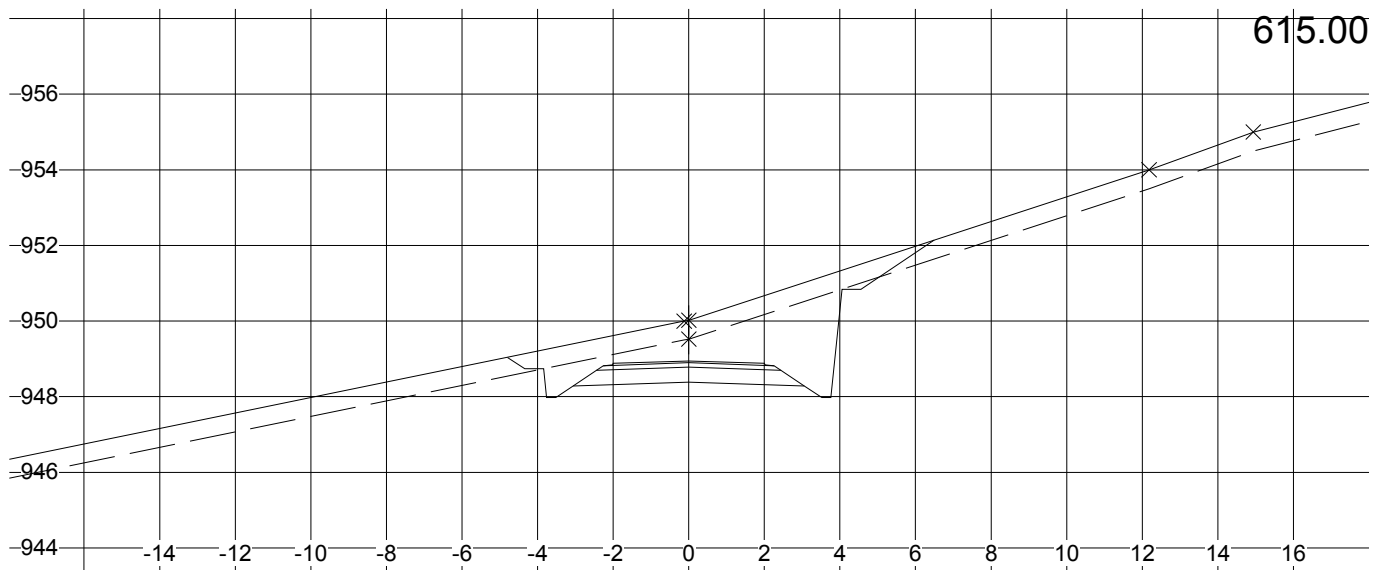
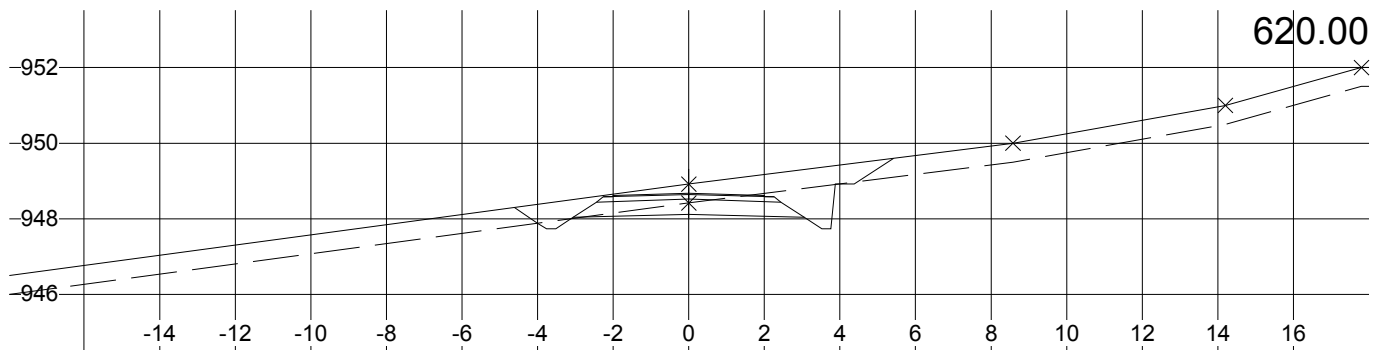

L:\IMA 4.7, Lisens: Plankontoret Hallvard Homme AS, Parsell: Parsell2.ps1

Rauland Invest AS Holtarvegen Veg2 Tverrprofil	Tegnet av AST	Saksbehandler
	Sidemannskontr.	Prosjektansvarlig AST
Plankontoret H. Homme AS 4747 Valle Tlf: 37 93 70 00, Fax: 37 93 74 74, E-Post: post@plankontoret.no	Dato 03.12.2009	Målestokk 1: 200 1: 200
	Prosj.nr. 2219-V2	
	Tegn.nr. Tp-53	Rev.

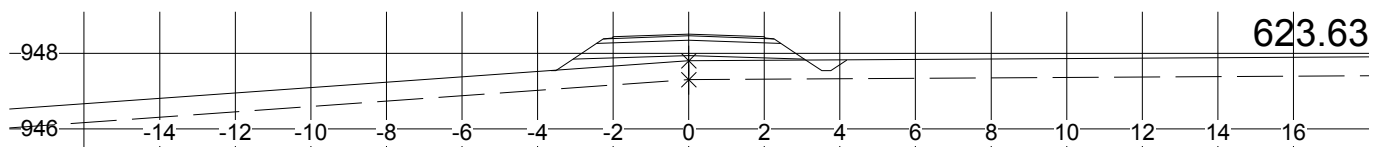

Rauland Invest AS Holtarvegen Veg2 Tverrprofil	Tegnet av AST	Saksbehandler
	Sidemannskontr.	Prosjektansvarlig AST
Plankontoret H. Homme AS 4747 Valle Tlf: 37 93 70 00, Fax: 37 93 74 74, E-Post: post@plankontoret.no	Dato 03.12.2009	Målestokk 1: 200
	Prosj.nr. 2219-V2	1: 200
	Tegn.nr. Tp-54	Rev.